



maxdivani

a book about warmth, nature and handmade comfort_



Slowing down, stopping, finally breathing.

Nature suggests slower times, inviting us to contemplation, rest, and maximum comfort.



| | | |
|-------------------|----------|---------|
| Sofas | 06-13 | Chicca |
| | 14-19 | Sipario |
| | 20-25 | Modula |
| | 26-31 | Norma |
| | 34-41 | Bogart |
| | 42-47 | Soprano |
| | 48-51 | Bolla |
| | 54-59 | Mia |
| | 60-65 | Morfeo |
| | 66-71 | Pierre |
| 72-77 | Tender | |
| 78-83 | Speciale | |
| 84-89 | Arona | |
| Armchairs | 92-95 | Muzzle |
| | 96-99 | Ember |
| | 100-103 | Scott |
| | 104-107 | Yuma |
| Beds | 110-115 | Muzzle |
| | 116-121 | Nel |
| Accessories | 124-129 | Muzzle |
| | 130-131 | Nel |
| | 132-135 | Tarkin |
| | 136-139 | Leia |
| Pillows & Carpets | 140-143 | |



beautiful changes display shades and lights_



mod. Leia
v. 501 - 1504

mod. Leia
v. 1501

Chicca _



mod. Chicca
v. 524-125-400-125-249



Chicca_



Concepito come un avvolgente e soffice abbraccio nel quale rifugiarsi in ogni momento della giornata, il modello modulare Chicca si distingue per le sue forme sinuose e tondeggianti, esaltate dal particolare gioco di cuciture che contribuisce con carattere a definirne i volumi.



Chicca armchair_



Designed to resemble a soft and cosy embrace in which to take refuge at any time of the day, the Chicca modular sofa features stand-out, signature curves and a rounded shape, with eye-catching stitching that makes a statement and defines the contours.



mod. Tarkin
v. 1515 - 502

Sipario_



mod. Sipario
v. 314 - 213



Design ricercato e dallo spirito accogliente per il modello angolare Sipario. Caratterizzato dall'andamento curvilineo della solida struttura in legno su cui sono alloggiate le sedute, è al contempo espressione di dinamismo grazie ai cuscini volanti in piuma d'oca che ne definiscono la spalliera.

Sipario_



An elegant yet cosy design for the Sipario corner sofa configuration. The eye-catching curved contour of the solid wooden structure supporting the seats also conveys a sense of movement thanks to the loose goose-down cushions arranged along the back





Modula_



mod. Modula
v. 310 - 249 - 721 - 245



Espressione di versatilità e dinamismo, il divano Modula, qui proposto in un'ampia soluzione angolare, è il risultato di una sapiente combinazione di versioni. Il modello si compone infatti di un divano due posti, cui abbiamo abbinato due chaise longue, disposte a creare un angolo retto. La composizione è chiusa tra due braccioli, impreziositi dal dettaglio sartoriale della trapuntatura orizzontale.

Modula_



mod. Modula
v. 308

An expression of versatility and dynamism, the Modula sofa, proposed here in a large corner version, is the result of a clever juxtaposition of modules. The model consists of a two-seater sofa combined with two chaise longues, arranged to create a right angle. The composition is closed by two armrests, embellished by the sartorial detail of the horizontal quilting.



Norma_



Norma_



mod. Norma
v. 300

L'unicità del modello Norma è rappresentata dal cuscino di seduta visibile da tutti lati, un cuscino molto ampio e alto che sostituisce la sponda, sottolineato da una basetta orizzontale in pelle che rigira verticalmente come parte del bracciolo.

Il bracciolo a mantellina, molto morbido, richiama il design e il comfort dei poggiatesta – reclinabili in più posizioni.



Norma_



mod. Norma
v. 304 - 200



The uniqueness of the Norma model is represented by the seat cushion visible from all sides, a very wide and high cushion that replaces the side, emphasized by a horizontal leather base that turns vertically as part of the armrest. The very soft cape armrest recalls the design and comfort of the headrests – reclining in multiple positions.



nature has created everything you can imagine_



mod. Leia
v. 1501 - 504

Bogart_



mod. Bogart
v. 310 - 403

Ricco di dettagli dalla trapuntatura della seduta e della spalliera al doppio colore della base e peculiarità importante la rifinitura con cucitura speciale ad X che caratterizza tutto il modello. Molto caratterizzanti sono le spalliere con meccanismo avanti – dietro manuale che aumentano la profondità del salotto di 26 cm.





mod. Bogart
v. 308



Full of details from the quilting of the seats and backrest to the double – coloured base, an important feature is the special X – stitch finishing that characterises the entire model. Back sliding system is a peculiarity of this product, increasing the depth of the sofa of about 26 cm.

Bogart_





mod. Scott
v. 105

mod. Tarkin
v. 1515- 502

Soprano_



La linea di Soprano ha un design molto ricercato, un'eleganza semplice ma con tanti dettagli preziosi. Il comfort ottimale è dato dalle imbottiture in piuma d'oca – tutta piuma per spalliera e cuscini e un mix per la seduta. Il modello Soprano è dotato di tre spalliere mobili, che consentono di crearsi la propria zona relax in qualunque punto del divano, caratterizzate da poggiatesta reclinabili inglobati nell'imbottitura.

Soprano_



mod. Soprano
v. 310 - 3811

Optimal comfort is given by the goose down padding – all down for the backrest and cushions and a mix for the seat. The Soprano model is equipped with three movable backrests, which allow you to create your own comfort area anywhere on the sofa, characterized by reclining headrests incorporated into the padding.





Bolla_



mod. Bolla
v. 308 - 200

Dal forte impatto estetico, il modello BOLLA strizza l'occhio al gusto vintage senza mai perdere di vista comfort e funzionalità. Dal design morbido e avvolgente, esaltato dalle cuciture curvilinee che definiscono sedute e braccioli assecondando l'andamento sinuoso delle imbottiture.

Aesthetically striking, the BOLLA model sports a vintage look without sacrificing comfort and functionality. With a soft and enveloping design, enhanced by the curvilinear seams that define seats and armrests, following the sinuous shape of the padding.



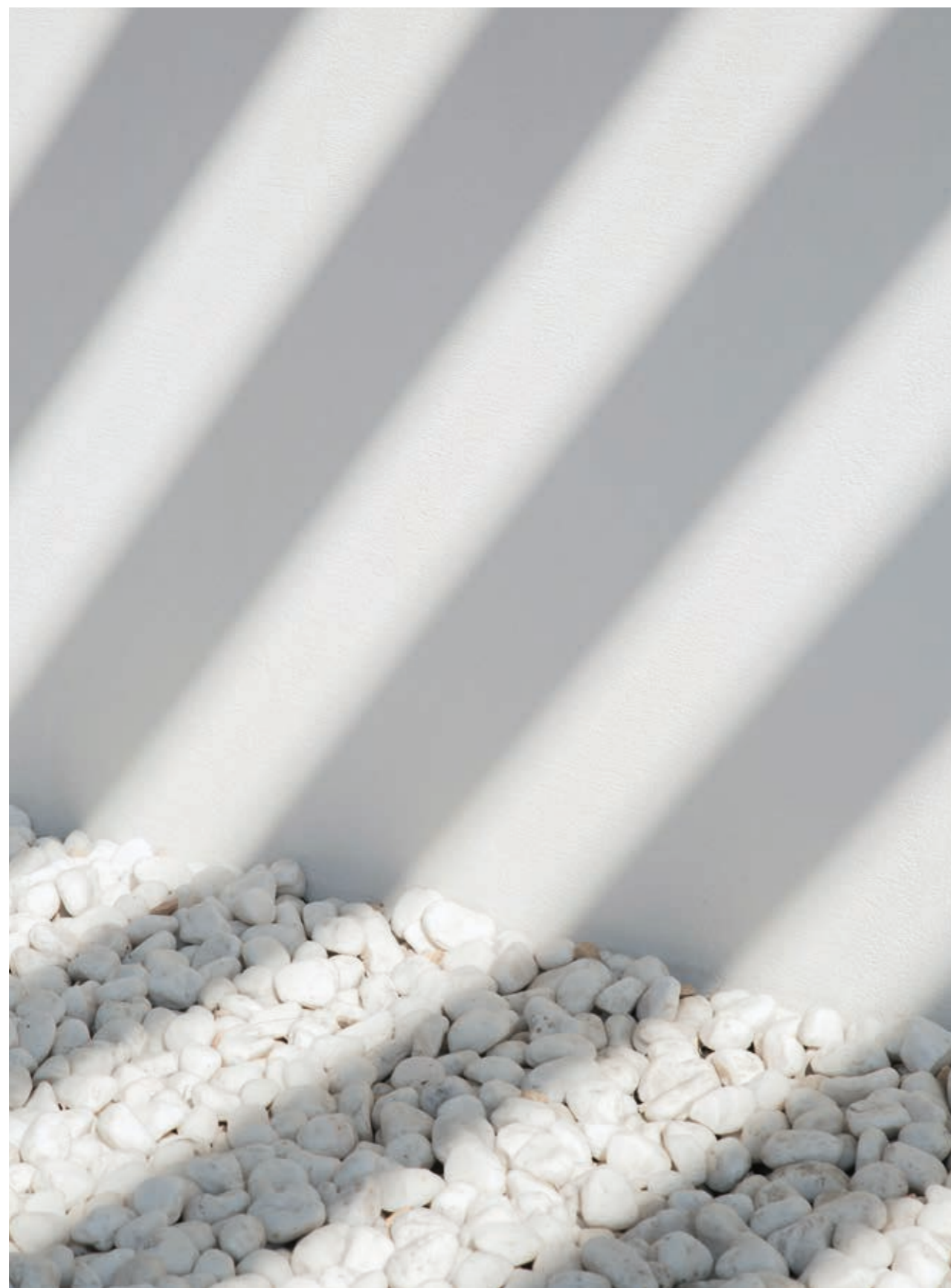

light can mirror reality without compromising form_



mod. Muzzle
v. 104 - 519 - 703

Mia_



mod. Mia
v. 230 - 125 - 113



Mia_



mod. Mia
v. 114 - 113





mod. Scott
v. 105

mod. Muzzle
v. 1712 - 519

Morfeo_



mod. Morfeo
v. 310 - 381



Appeal contemporaneo e design caratterizzato dalla spiccata linearità sono i tratti distintivi del modello, un perfetto compromesso tra estetica e comfort. Personalizzabile negli abbinamenti dei rivestimenti, Morfeo si distingue infine per la base aperta ed ariosa, sollevata da terra di ben venti centimetri

Morfeo_



Modern appeal and design characterized by marked linearity are the hallmarks of the model, a perfect compromise between aesthetics and comfort. Customizable in the combinations of coverings, Morfeo finally stands out for its open and airy base, raised from the ground by a good twenty centimetres.



Pierre_



mod. Lipari 90
Lipari 72

Pierre_



Soluzione ideale per arredare con carattere la zona living, il modello Pierre è un ampio divano componibile che coniuga idealmente comfort e design. Caratterizzato da volumi solidi e compatti, dotato in ogni poltrona di doppi meccanismi automatici.

The ideal solution for add a touch of style to the living room, Pierre model is a spacious modular sofa - the perfect combination of comfort and design. This model has a solid, compact appearance and includes double automatic mechanisms.



mod. Pierre
v. 2196 - 103 - 2197

Pierre_



Tender_



Tender_



Tecnologia al servizio della migliore esperienza di relax, racchiusa in un'animo soffice e accogliente: questo lo spirito del modello componibile Tender, dotato di meccanismo che consente di aprire la pediera e reclinare il poggiatesta azionando un unico pulsante elettrico. Caratterizzato nel design dai braccioli dal particolare profilo asimmetrico e poggiato su solide slitte in metallo in sei diverse finiture.



Tender_



mod. Tender
v. 2168 - 2169

Technology creating the very best relaxation experience centred around softness and comfort - this is the spirit of the Tender modular sofa, featuring a mechanism that allows you to open the footrest and recline the headrest by pressing a single electric button. The design of the armrests features a distinctive asymmetrical profile and the solid metal sled supports come in six different finishes.



mod. Tender
v. 2168 - 2169 - 102 - 101



Speciale_



Speciale_



mod. Speciale
v. 5168 - 720 - 5169 - 608

Pensato per offrire un'indimenticabile esperienza di comfort, il modello componibile Speciale è dotato in ogni poltrona di un doppio meccanismo recliner - presente sia nella pediera che nella spalliera - azionabile simultaneamente in un unico gesto, tramite pulsantiera elettrica o manualmente.



Speciale_



mod. Speciale
v. 5168 - 5169 - 608

The design of the Speciale modular sofa is all about long-lasting comfort. It features an armchair module with a double recliner mechanism in both the footrest and backrest which can be operated with a single push of a button using an electric or manual control device.



Arona_



mod. Nel
v. 1519

mod. Arona
v. 2196 - 103 - 2197

Arona_



mod. Arona
v. 2168 - 2169 - 102 - 101

Pensato come soluzione perfetta per la zona living, il modello modulare Arona qui proposto nella versione a due o tre posti, è l'ideale compromesso tra comfort ed estetica. Dai volumi solidi e compatti, questo divano si caratterizza per i pregevoli elementi decorativi presenti nei braccioli e costituiti da una fascia in pelle a contrasto che va ad integrarsi con la slitta in metallo su cui poggia l'intera struttura.



Arona_



mod. Arona
v. 114 - 113

Designed as a perfect solution for the living area, the Arona modular model, presented in the two- or three-seater version, is the ideal compromise between comfort and aesthetics. With solid and compact volumes, this sofa is characterized by the fine decorative elements in the armrests consisting of a contrasting leather band integrated with the metal sled on which the entire structure rests.



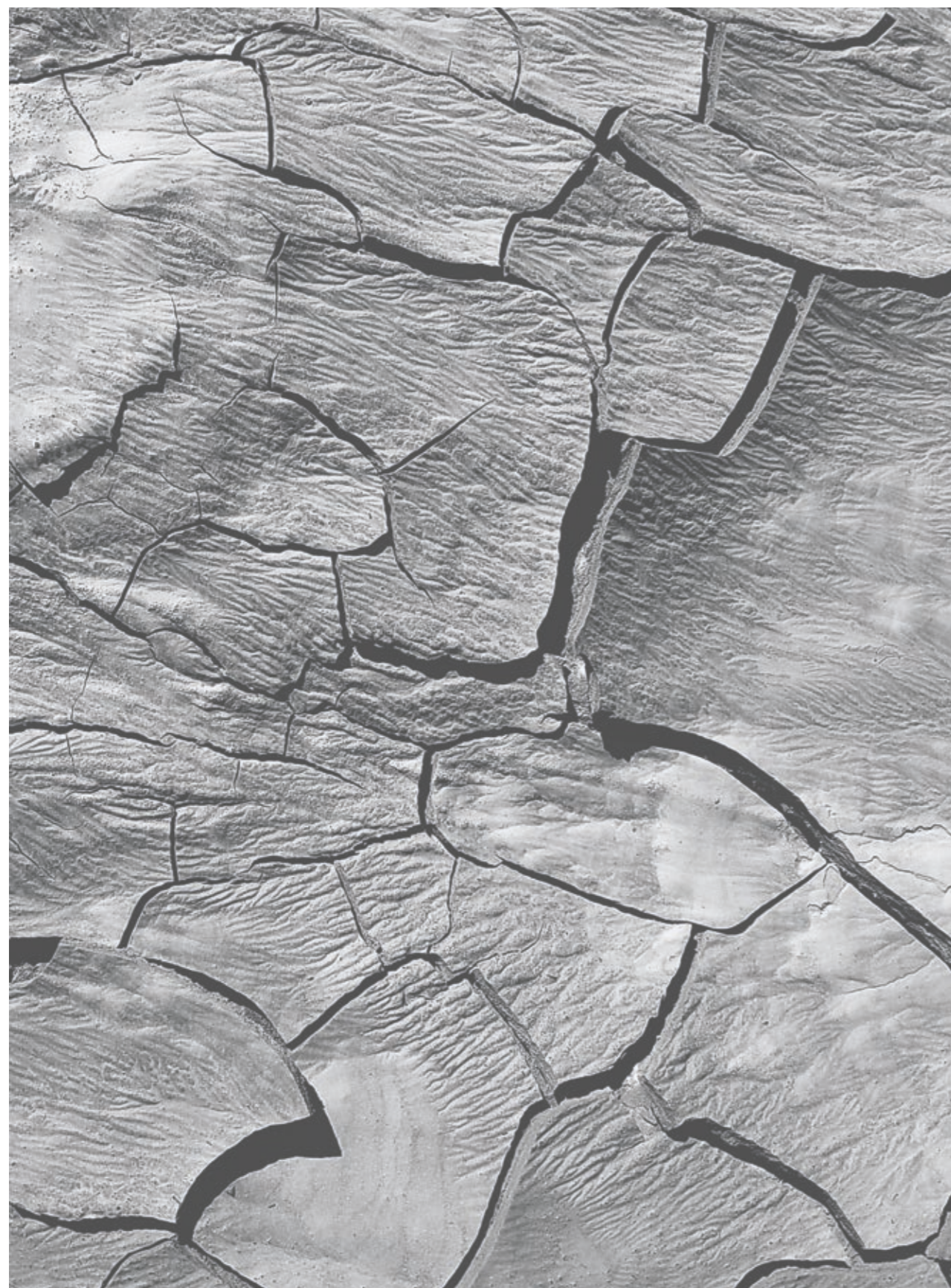

nature always inspires us_

Muzzle armchair_



mod. Muzzle
v. 104 - 104 - 703

Muzzle armchair_



Definita da una seduta avvolgente, rivestita in pregiato velluto grigio platino la cui esclusiva lavorazione trapuntata crea un raffinato gioco tridimensionale di luci e ombre, la poltrona a pozzetto Muzzle è la quintessenza della cura artigianale unita al comfort.

With its statement wrap-around seat, upholstered in elegant platinum grey velvet with a quilted pattern that creates a sophisticated three-dimensional play of light and shadows, the Muzzle tub chair is the epitome of artisan craftsmanship combined with comfort.



mod. Muzzle
v. 104



Ember armchair_





Ember armchair_



mod. Ember
v. 104

Spirito giocoso e versatile per la deliziosa poltroncina a pozzetto Ember. Ideale per definire un angolo relax, arreda con agilità qualsiasi spazio - anche il più contenuto - che richieda un'oasi di comfort.

The delightful Ember tub chair has a playful, versatile air. Ideal for creating a relaxation zone, it seamlessly furnishes any space - even the smallest - to create a haven of comfort.



Scott armchair_





Scott armchair_

Dal forte appeal contemporaneo e destinata ad arredare con carattere ogni ambiente, la poltrona Scott si distingue per la sua particolare forma angolare senza braccioli, al tempo ricercata ed accogliente.

With a strong contemporary appeal that injects character into any setting, the Scott armchair features a distinctive angular shape - with no armrests - which is both elegant and welcoming.



mod. Scott
v. 105





Il gusto vagamente vintage della poltroncina a pozzetto, vive una seconda giovinezza grazie a YUMA, dal design curvilineo e ricercato. Ideale per la zona living e gli ambienti di lavoro, questa poltrona è pensata per rendere più confortevoli - grazie alla sua seduta con cuscino imbottito - riunioni e momenti di attesa.

mod. Yuma
v. 105



The vaguely vintage style of the tub chair is given a second lease of life thanks to YUMA with its curved and elegant design. Ideal for the living room or work spaces, this armchair is designed to make meetings and waiting more comfortable with its upholstered seat cushion.





comfort depends on soft rounded shapes not sharp corners_

Muzzle bed_



mod. Muzzle
v. 913 - 521
1711 - 1509 - 104

Muzzle bed_



mod. Muzzle
v. 913 - 521



Muzzle bed_



Funzionalità e ricercatezza estetica trovano il loro perfetto connubio nel letto matrimoniale Muzzle. La sua ampia testiera, definita da profili in metallo, è rivestita in pregiato velluto grigio platino, la cui esclusiva lavorazione trapuntata crea un elegante gioco tridimensionale di luci e ombre. A completamento dell'arredo della camera da letto, abbiamo abbinato la panca, la poltroncina ed i pouff coordinati.

Functionality meets aesthetic elegance in the Muzzle double bed. The extra-large headboard, with a metal profile, is upholstered in stylish platinum grey velvet featuring an exclusive quilted pattern that creates an elegant three-dimensional play of light and shadows. The bedroom set is completed with a matching bench, armchair and coordinated poufs.



Nel bed_



mod. Nel
v. 913 - 521 - 519

mod. Ember
v. 104

Nel bed_



Essenziale nelle linee ma mai scontato, Nel è un letto matrimoniale in cui coesistono proporzioni, design e comfort. La testiera, rivestita in un sobrio e rilassante tessuto con cuciture pizzicate a contrasto, è segnata dalla presenza di una "clip" decorativa in metallo che - creando una lieve angolatura - conferisce dinamismo all'intera struttura. Possibile abbinamento con panca e pouff coordinati.

With simple but far from predictable lines, Nel is a double bed that combines proportions, design and comfort. The headboard, upholstered in a soft, relaxing fabric and contrasting gathered stitching, features a signature decorative metal "clip" that creates a slight angle and adds a sense of movement to the structure. Optional matching bench and pouf.



Nel bed_



mod. Nel
v. 913 - 521



colours influence how we see nature_



Muzzle wood low & high Coffee Tables
v. 1712 - 703



Muzzle pouf
v. 519





Muzzle Coffee Table
v. 1509



Muzzle double CoffeeTable
v. 1711



Muzzle stone Low Table
v. 1712





Nel Coffee Table
v. 1519



Nel Pouf
v. 509



Nel Coffee Table
v. 1519



Tarkin Coffee Table
v. 1515

Dalle forme essenziali e rivestiti nelle tonalità neutre degli elementi naturali, i complementi d'arredo Tarkin si caratterizzano per il design arrotondato, ispirato al profilo dei ciottoli levigati dalle acque di un fiume.

With minimalist shapes and covered in the neutral shades of the natural elements, the Tarkin furnishing accessories are characterised by their rounded design, inspired by the profile of pebbles smoothed by the waters of a river.



Tarkin Poufs
v. 515 - 502

Tarkin accessories_



Tarkin Poufs
v. 505 - 502





Avvolti in un'ampia fascia chiusa da due bottoni decorativi, i pouf e i tavolini da caffè Leila imitano con spirito irriverente il polsino di una camicia. Il loro stile però è tutt'altro che formale! Giocando con abbinamenti inediti di colori, rivestimenti e trame, sapranno regalare alla zona living un tocco di dinamismo e vivacità ed insieme accogliere ogni momento conviviale e di relax.



Leia Coffee Table
V. 1504

Leia accessories_



Leia Pouf
v. 504



Leia Coffee Table
v. 1501

Wrapped in a wide band closed by two decorative buttons, the Leia poufs and coffee tables imitate with an irreverent spirit a shirt's cuff. Their style, however, is anything but formal! Playing with new combinations of colours, coverings, and textures, they will give the living area a touch of dynamism and liveliness while welcoming every moment of conviviality and relaxation.



Pocket pillows_



Pocket 04 - 50x35 cm - 20"x 14"



Pocket 02 - 50x35 cm - 20"x 14"

Sempre disponibili ad offrire un plus di comfort, i pocket pillows sono soffici cuscini da salotto, ma con una marcia in più. Dotati di una comoda ed ampia tasca porta tutto, sono perfetti per riporvi ed avere sempre a portata di mano tutto il necessario per rendere perfetta la pausa relax.

Always available to offer additional comfort, the Pocket pillows are soft cushions for the living room, but with something special. Featuring a comfortable and large pocket, they are perfect for storing and always having at hand everything you need to make your breaks perfect.



Pocket 05 - 40x40 cm - 16"x 16"



Pocket 01 - 55x40 cm - 22"x 16"



Pocket 03 - 55x30 cm - 22"x 12"

Nuance neutre e facilmente declinabili, ispirate alle texture dei paesaggi e degli elementi naturali: in poche parole il tratto distintivo di questa collezione tappeti. Perfetti per creare un'atmosfera morbida, accogliente e che inviti alla contemplazione, sono il complemento ideale per incorniciare ed esaltare qualsiasi tipo di arredo.

Neutral nuances that are easy to pair, inspired by the textures of landscapes and natural elements: the distinctive feature of this rug collection in a nutshell. Perfect for creating a soft, welcoming atmosphere that invites contemplation, they are the ideal accessory to frame and enhance any type of decor.

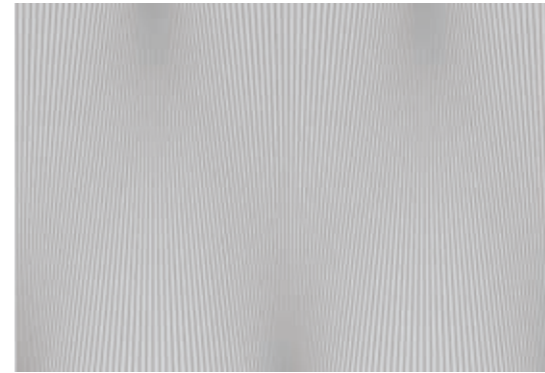

Stillness Grey



Stillness Beige



Flash Grey



Flash Beige

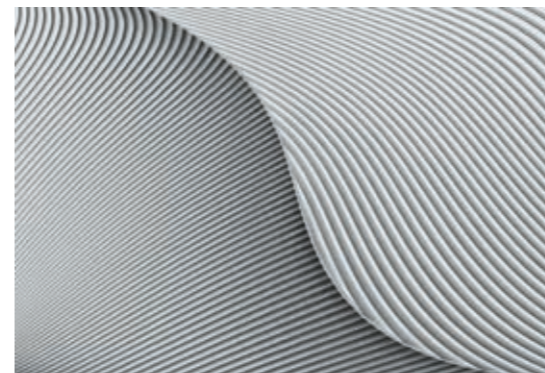

Dune Grey



Dune Rose



Fluid Beige



Fluid Olive



Schede tecniche

Technical sheet

Arona_



patented model

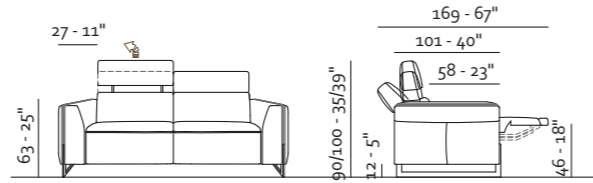

Esempi di componibilità - Sectionals examples - Exemples de compositions - Ejemplos de modularidad

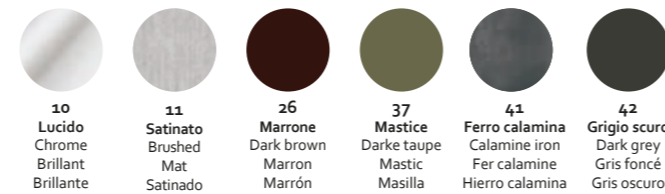
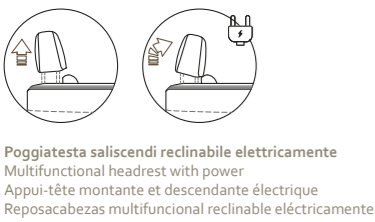
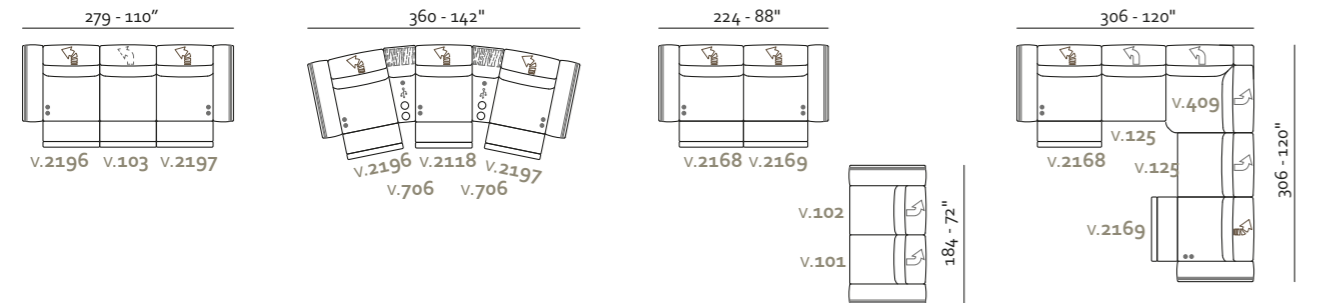

Bogart_

patented model

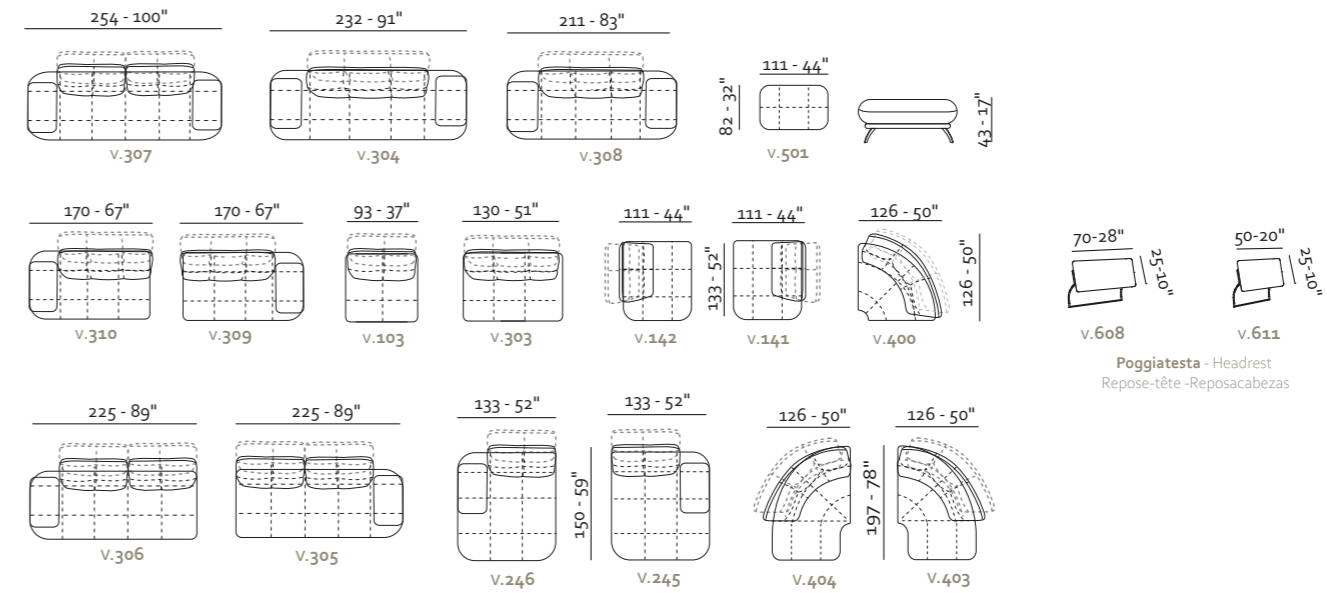
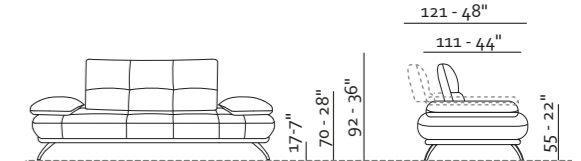

Esempi di componibilità - Sectionals examples - Exemples de compositions - Ejemplos de modularidad

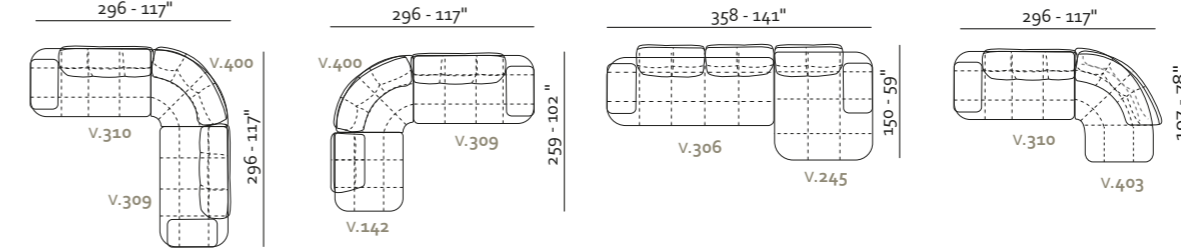

— Finitura piedi / Legs finishes
Finition de pieds / Acabados de pies

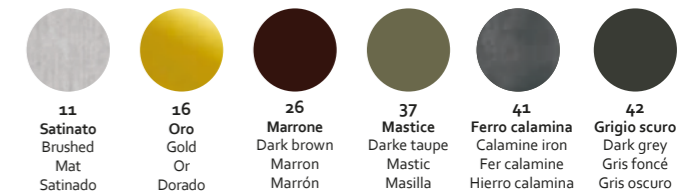

Bolla_

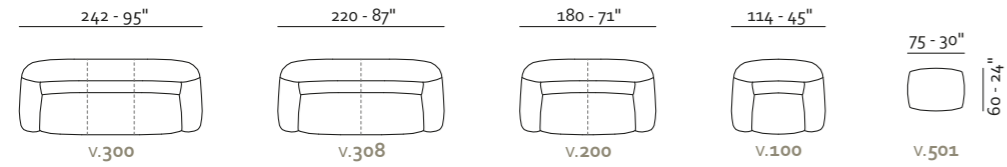

patented model

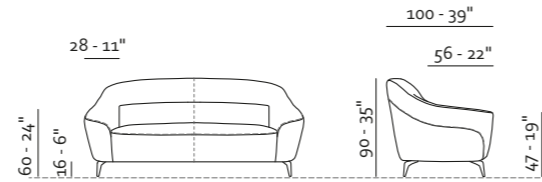

Chicca_

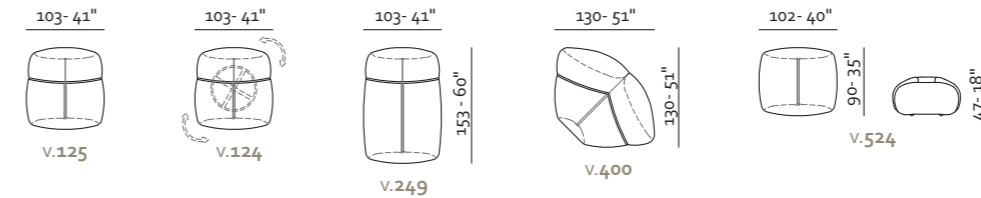

Esempi di componibilità - Sectionals examples - Exemples de compositions - Ejemplos de modularidad

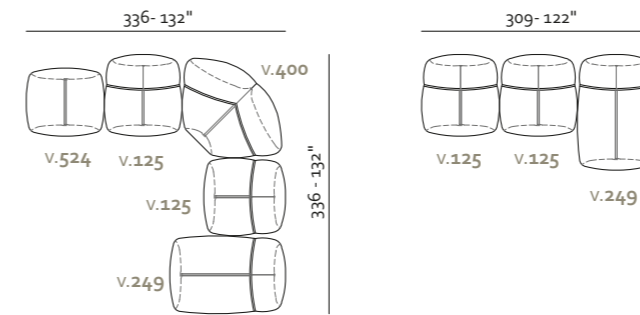

patented model

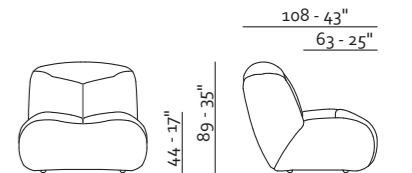

- **Rivestimento**
Pelle / Tessuto
- **Imbottitura**
BRACCIOLI / Poliuretano espanso
SEDUTA / Poliuretano espanso
SPALLIERA / Poliuretano espanso
- **Opzioni** Cucitura a contrasto
- **Comfort** Standard
- **Piedi** Metallo
- **Struttura** Telaio in legno

- **Coverings**
Leather / Fabric
- **Filling**
ARMS / Foam
SEAT CUSHION / Foam
BACK CUSHION / Foam
- **Options** Contrast stitching
- **Comfort** Standard
- **Legs** Metal
- **Structure** Wooden frame

- **Revêtement**
Cuir / Tissu
- **Rembourrage**
ACCOUDOIRS / Mousse
ASSISE / Mousse
DOSSIER / Mousse
- **Options** Coutures contrastées
- **Comfort** Standard
- **Pieds** Metal
- **Structure** Structure en bois

- **Revestimiento**
Piel / Tela
- **Imbottitura**
APOYABRAZOS / Poliuretano expandido
SENTADA / Poliuretano expandido
RESPALDO / Poliuretano expandido
- **Opciones** Costura en contraste
- **Comfort** Estándar
- **Pies** Metal
- **Struttura** Estructura en madera

- **Molle greche**
— Zig Zag springs
— Sangles métalliques nozag
— Muelles ondulados



- **Finitura piedi** / Legs finishes
Finition de pieds / Acabados de pies



- **Rivestimento**
Pelle / Tessuto
- **Imbottitura**
BRACCIOLI / Poliuretano espanso
SEDUTA / Poliuretano espanso
SPALLIERA / Poliuretano espanso
- **Opzioni** Cucitura a contrasto
- **Comfort** Standard
- **Piedi** Plastica
- **Struttura** Telaio in legno

- **Coverings**
Leather / Fabric
- **Filling**
ARMS / Foam
SEAT CUSHION / Foam
BACK CUSHION / Foam
- **Options** Contrast stitching
- **Comfort** Standard
- **Legs** Plastic
- **Structure** Wooden frame

- **Revêtement**
Cuir / Tissu
- **Rembourrage**
ACCOUDOIRS / Mousse
ASSISE / Mousse
DOSSIER / Mousse
- **Options** Coutures contrastées
- **Comfort** Standard
- **Pieds** Plastique
- **Structure** Structure en bois

- **Revestimiento**
Piel / Tela
- **Imbottitura**
APOYABRAZOS / Poliuretano expandido
SENTADA / Poliuretano expandido
RESPALDO / Poliuretano expandido
- **Opciones** Costura en contraste
- **Comfort** Estándar
- **Pies** Plástico
- **Struttura** Estructura en madera

Mia_

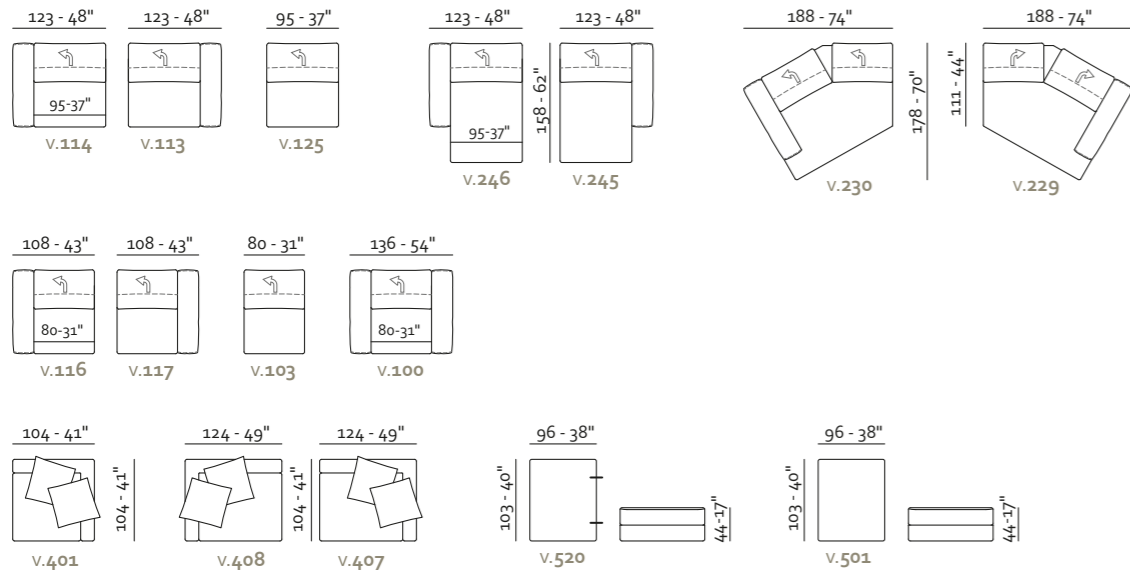

Esempi di componibilità - Sectionals examples - Exemples de compositions - Ejemplos de modularidad

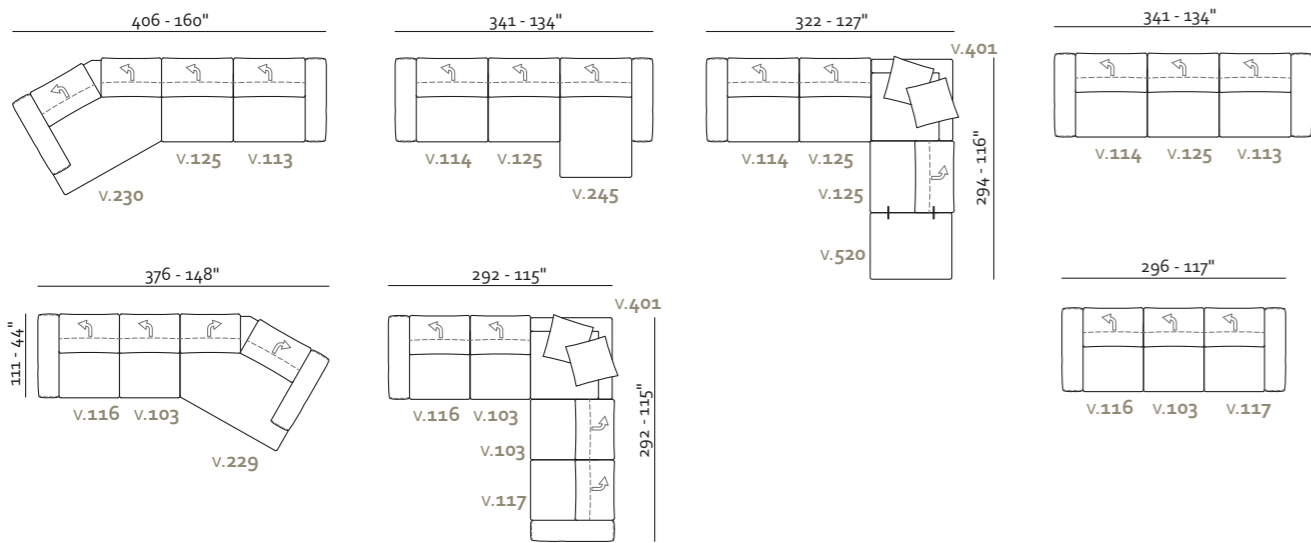

Modula_

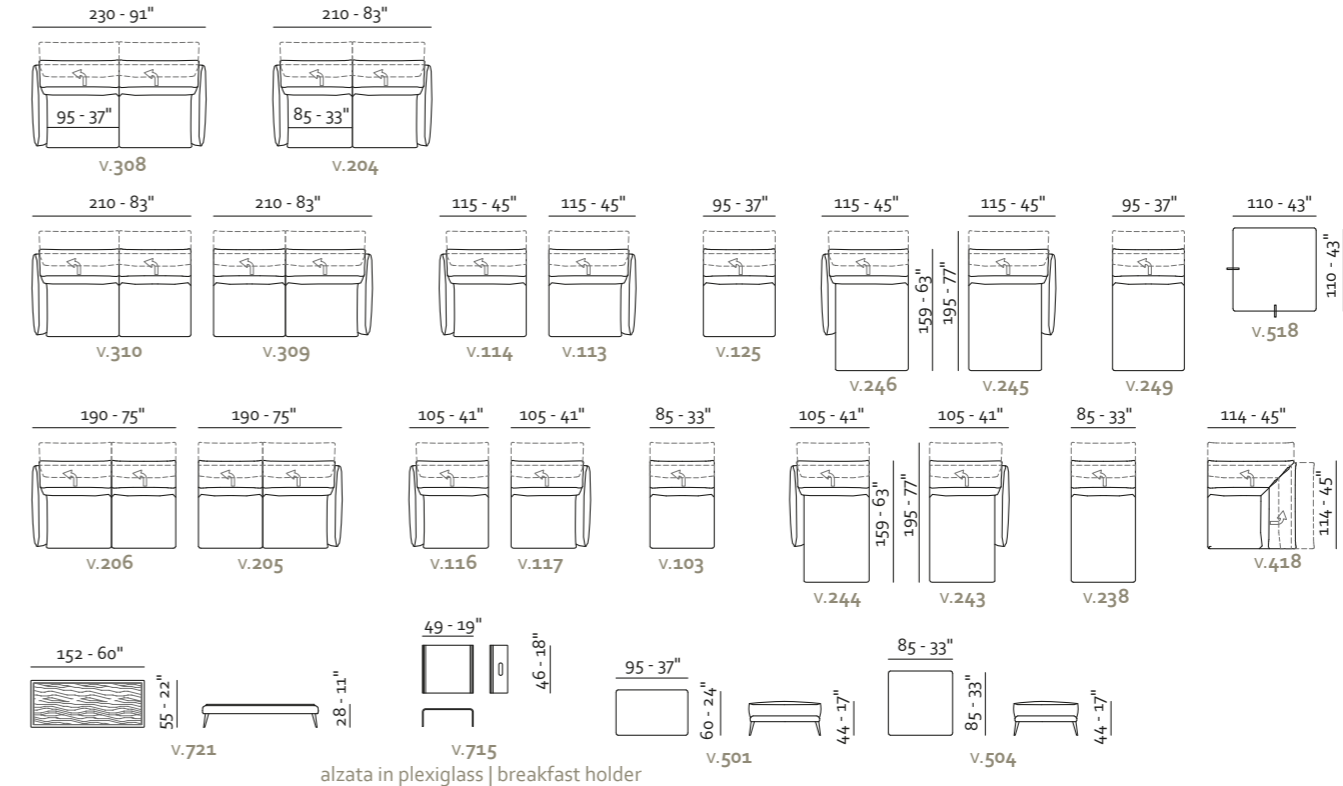
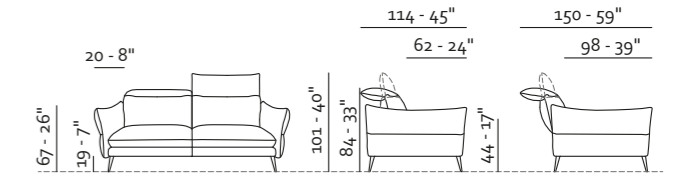

Esempi di componibilità - Sectionals examples - Exemples de compositions - Ejemplos de modularidad

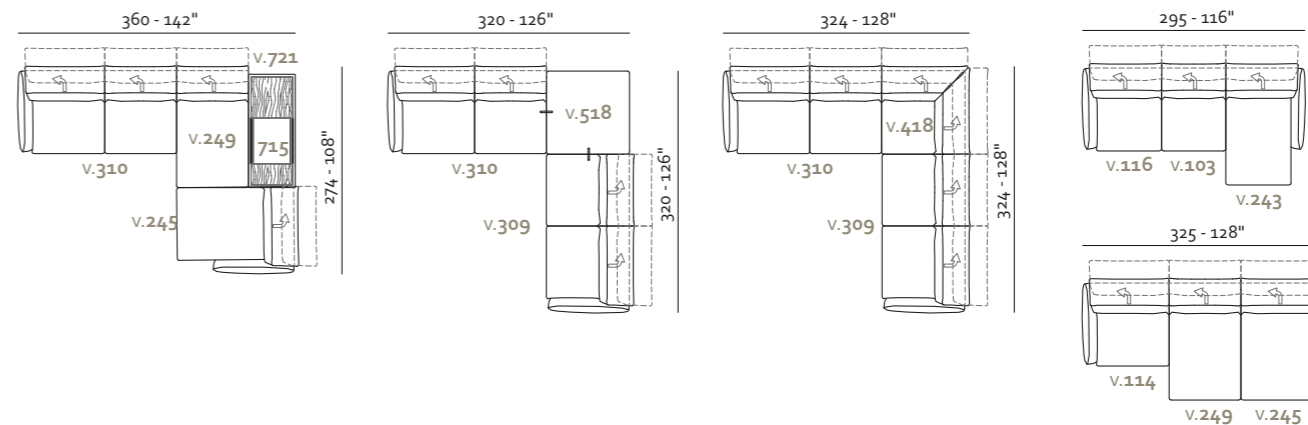

patented model

- Rivestimento
Pelle / Tessuto
- Imbottitura
BRACCIOLI / Poliuretano espanso
SEDUTA / Poliuretano espanso
SPALLIERA / Poliuretano espanso
- Opzioni Cucitura a contrasto
- Comfort Standard
- Piedi Metallo
- Struttura Telaio in legno

- Coverings
Leather / Fabric
- Filling
ARMS / Foam / Feather
SEAT CUSHION / Foam
BACK CUSHION / Foam
- Options Contrast stitching
- Comfort Standard
- Legs Metal
- Structure Wooden frame

- Revêtement
Cuir / Tissu
- Rembourrage
ACCOUDOIRS / Mousse / Plumes
ASSISE / Mousse
DOSSIER / Mousse
- Options Coutures contrastées
- Comfort Standard
- Pieds Metal
- Structure Structure en bois

- Revestimiento
Piel / Tela
- Imbottitura
APOYABRAZOS / Poliuretano expandido / Piuma
SENTADA / Poliuretano expandido
RESPALDO / Poliuretano expandido
- Opciones Costura en contraste
- Comfort Estándar
- Pies Metal
- Struttura Estructura en madera

- Finitura piedi / Legs finishes
Finition de pieds / Acabados de pies

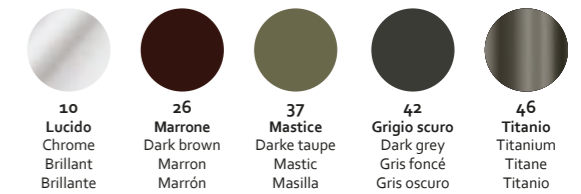

Morfeo_

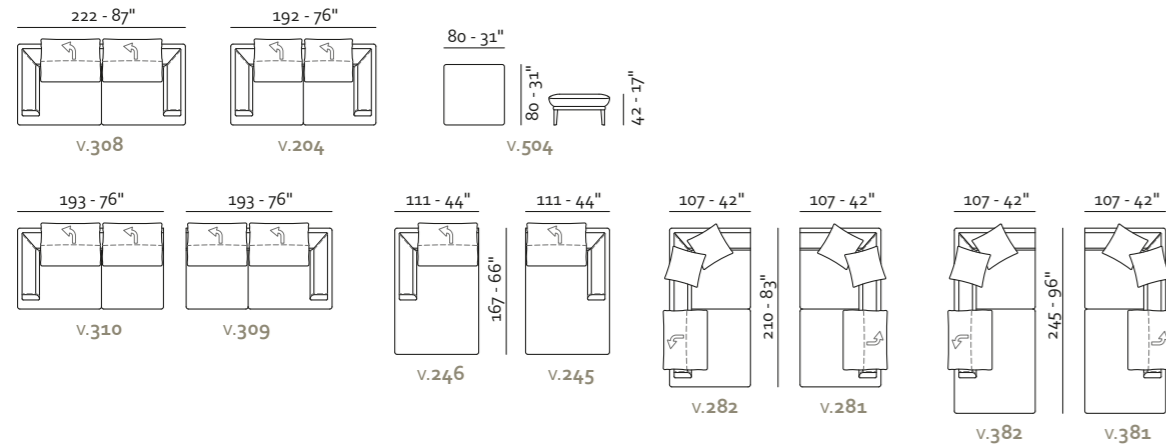

Esempi di componibilità - Sectionals examples - Exemples de compositions - Ejemplos de modularidad

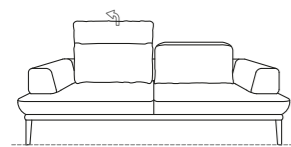
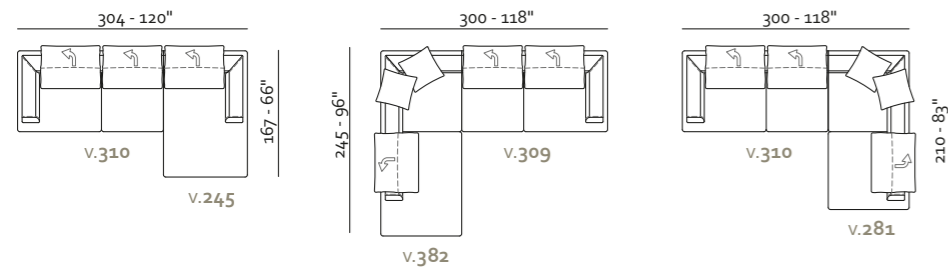

Rivestimento / Coverings
Revêtement / Revestimiento

A

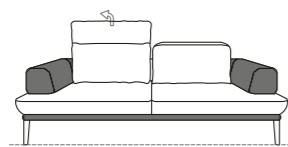

Rivestimento / Coverings
Revêtement / Revestimiento

B

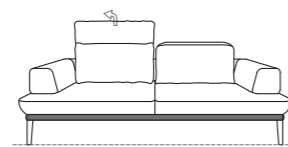

Rivestimento / Coverings
Revêtement / Revestimiento

C

patented model

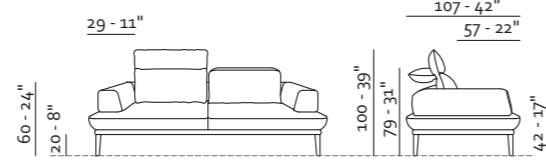

- Rivestimento
Pelle / Tessuto
- Imbottitura
BRACCIOLI / Poliuretano espanso
SEDUTA / Poliuretano espanso
SPALLIERA / Poliuretano espanso
- Opzioni Cucitura a contrasto
- Comfort Standard
- Piedi Metallo
- Struttura Telaio in legno
- Coverings
Leather / Fabric
- Filling
ARMS / Foam
SEAT CUSHION / Foam
BACK CUSHION / Foam
- Options Contrast stitching
- Comfort Standard
- Legs Metal
- Structure Wooden frame

- Revêtement
Cuir / Tissu
- Rembourrage
ACCOUDOIRS / Mousse
ASSISE / Mousse
DOSSIER / Mousse
- Options Coutures contrastées
- Comfort Standard
- Pieds Metal
- Structure Structure en bois

- Revestimiento
Piel / Tela
- Imbottitura
APOYABRAZOS / Poliuretano expandido
SENTADA / Poliuretano expandido
RESPALDO / Poliuretano expandido
- Opciones Costura en contraste
- Comfort Estándar
- Pies Metal
- Estructura Estructura en madera

- Finitura piedi / Legs finishes
Finition de pieds / Acabados de pies



10
Lucido
Chrome
Brillante



11
Satinato
Brushed
Mat
Satinado



22
Bronzato
Bronze
Bronce



Poggiatesta reclinabile
Reclining headrest
Appui-tête ajustable
Reposacabezas reclinable

Norma_

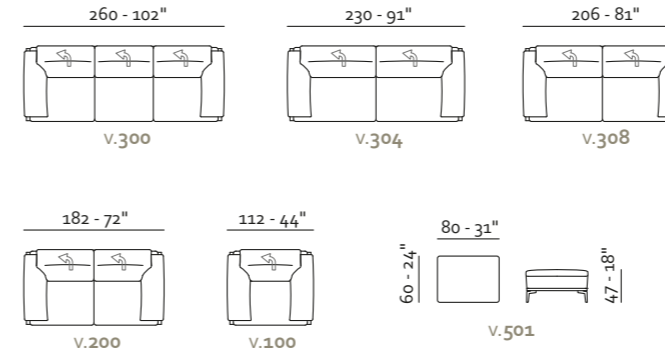

patented model

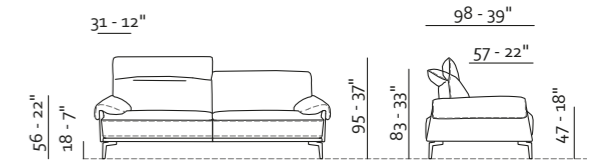

- Rivestimento
Pelle / Tessuto
- Imbottitura
BRACCIOLI / Poliuretano espanso
SEDUTA / Poliuretano espanso
SPALLIERA / Poliuretano espanso
- Opzioni Cucitura a contrasto
- Comfort Standard
- Piedi Metallo
- Struttura Telaio in legno
- Coverings
Leather / Fabric
- Filling
ARMS / Foam
SEAT CUSHION / Foam
BACK CUSHION / Foam
- Options Contrast stitching
- Comfort Standard
- Legs Metal
- Structure Wooden frame

- Revêtement
Cuir / Tissu
- Rembourrage
ACCOUDOIRS / Mousse
ASSISE / Mousse
DOSSIER / Mousse
- Options Coutures contrastées
- Comfort Standard
- Pieds Metal
- Structure Structure en bois

- Revestimiento
Piel / Tela
- Imbottitura
APOYABRAZOS / Poliuretano expandido
SENTADA / Poliuretano expandido
RESPALDO / Poliuretano expandido
- Opciones Costura en contraste
- Comfort Estándar
- Pies Metal
- Estructura Estructura en madera

- Molle greche
— Zig Zag springs
— Sangles métalliques nozag
— Muelles ondulados



- Finitura piedi / Legs finishes
Finition de pieds / Acabados de pies



10
Lucido
Chrome
Brillante



11
Satinato
Brushed
Mat
Satinado



22
Bronzato
Bronze
Bronce



46
Titanio
Titanium
Titane

Pierre_

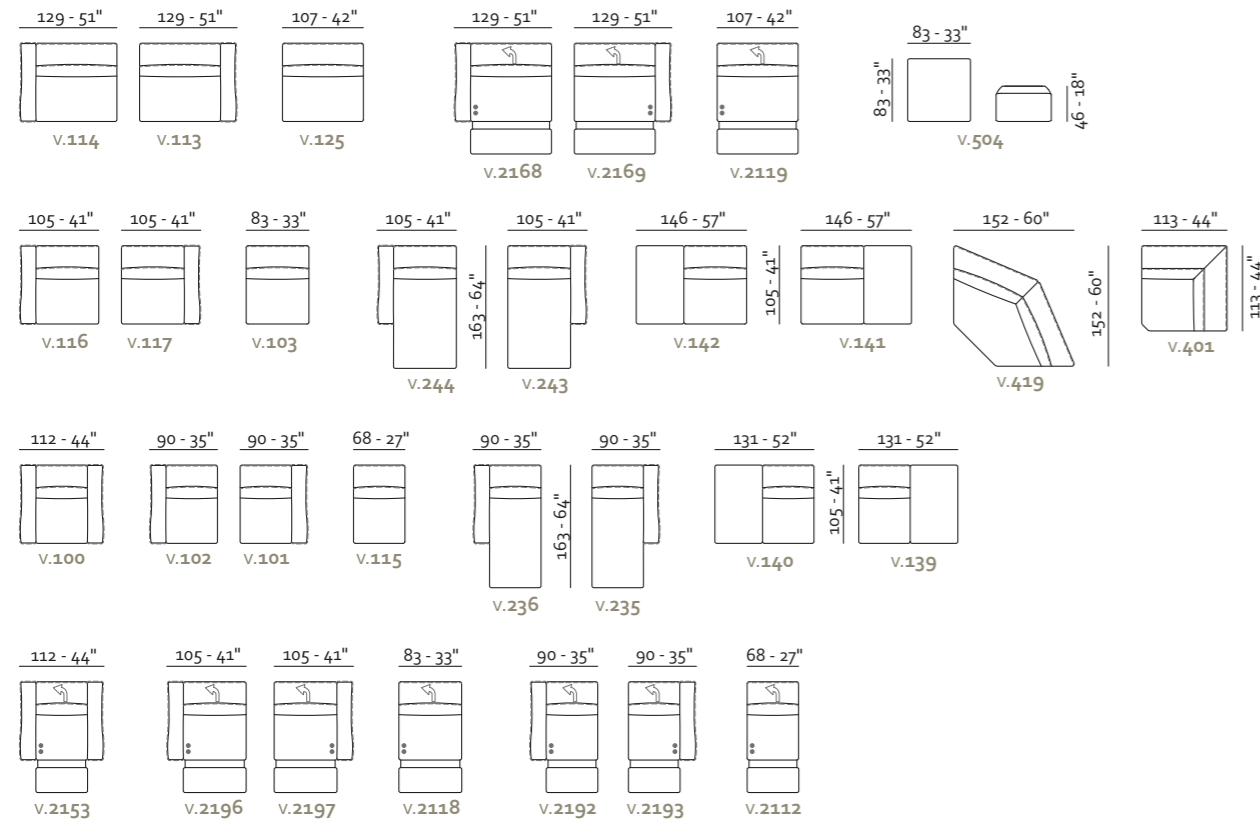

Esempi di componibilità - Sectionals examples - Exemples de compositions - Ejemplos de modularidad

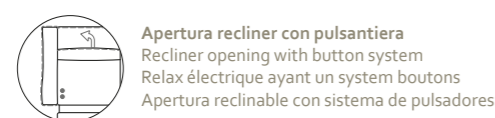
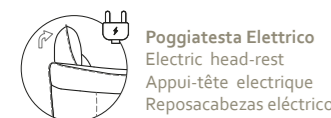
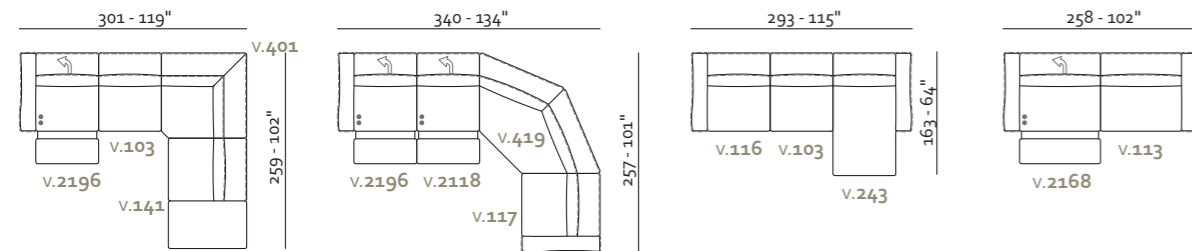

Sipario_

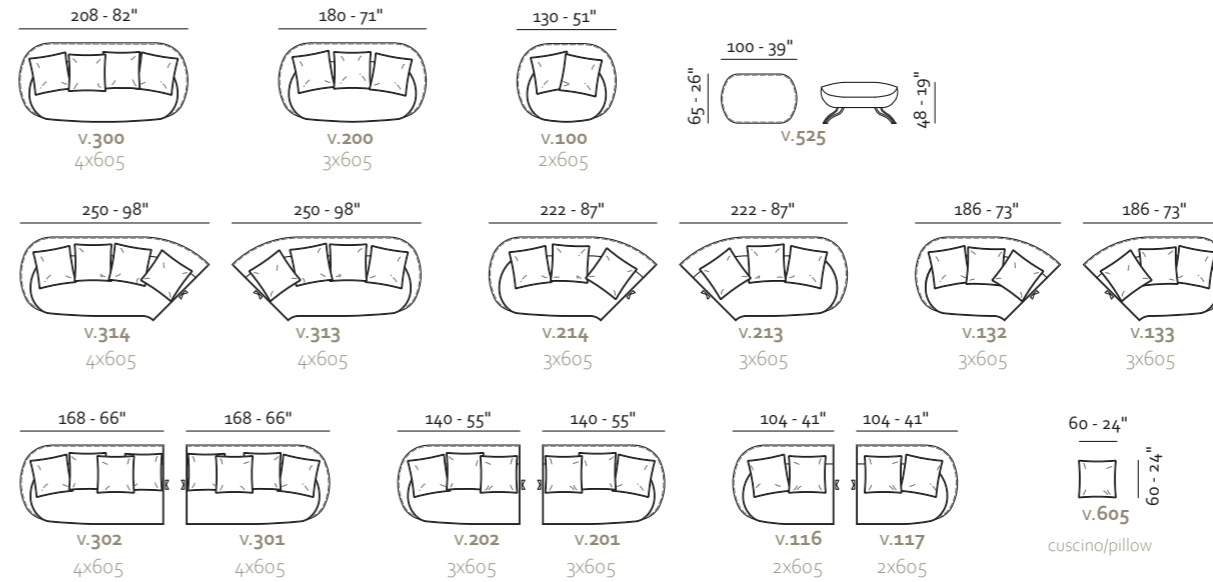
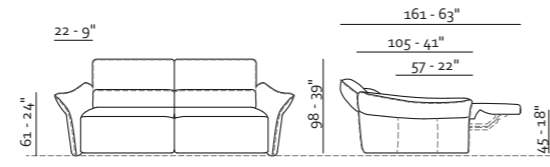

Esempi di componibilità - Sectionals examples - Exemples de compositions - Ejemplos de modularidad

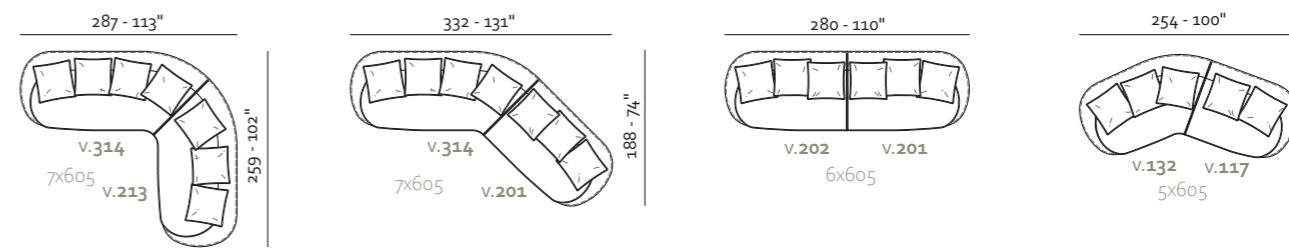

- Rivestimento
Pelle / Tessuto
- Imbottitura
BRACCIOLI / Poliuretano espanso
SEDUTA / Poliuretano espanso
SPALLIERA / Poliuretano espanso
- Opzioni Cucitura a contrasto
- Comfort Standard / Rigido
- Piedi Plastica
- Struttura Telaio in legno

- Coverings
Leather / Fabric
- Filling
ARMS / Foam
SEAT CUSHION / Foam
BACK CUSHION / Foam
- Options Contrast stitching
- Comfort Standard / Hard
- Legs Plastic
- Structure Wooden frame

- Revêtement
Cuir / Tissu
- Rembourrage
ACCOUDOIRS / Mousse
ASSISE / Mousse
DOSSIER / Mousse
- Options Coutures contrastées
- Comfort Standard / Fermé
- Pieds Plastique
- Structure Structure en bois

- Revestimiento
Piel / Tela
- Imbottitura
APOYABRAZOS / Poliuretano expandido
SENTADA / Poliuretano expandido
RESPALDO / Poliuretano expandido
- Opciones Costura en contraste
- Comfort Estándar / Duro
- Pies Plástico
- Struttura Estructura en madera

- Molle insacchettate
— Pocket springs
— Ressorts ensachés
— Muelles ensacados



patented model

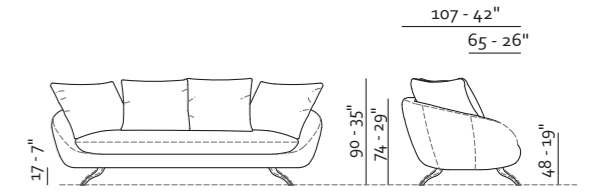

- Rivestimento
Pelle / Tessuto
- Imbottitura
BRACCIOLI / Poliuretano espanso
SEDUTA / Poliuretano espanso / Piuma
SPALLIERA / Piuma
- Opzioni Cucitura a contrasto
- Comfort Standard
- Piedi Metallo
- Struttura Telaio in legno

- Coverings
Leather / Fabric
- Filling
ARMS / Foam
SEAT CUSHION / Foam / Feather
BACK CUSHION / Feather
- Options Contrast stitching
- Comfort Standard
- Legs Metal
- Structure Wooden frame

- Revêtement
Cuir / Tissu
- Rembourrage
ACCOUDOIRS / Mousse
ASSISE / Mousse / Plumes
DOSSIER / Plumes
- Options Coutures contrastées
- Comfort Standard
- Pieds Metal
- Structure Structure en bois

- Revestimiento
Piel / Tela
- Imbottitura
APOYABRAZOS / Poliuretano expandido
SENTADA / Poliuretano expandido / Piuma
RESPALDO / Piuma
- Opciones Costura en contraste
- Comfort Estándar
- Pies Metal
- Struttura Estructura en madera

- Finitura piedi / Legs finishes
Finition de pieds / Acabados de pies



Soprano_

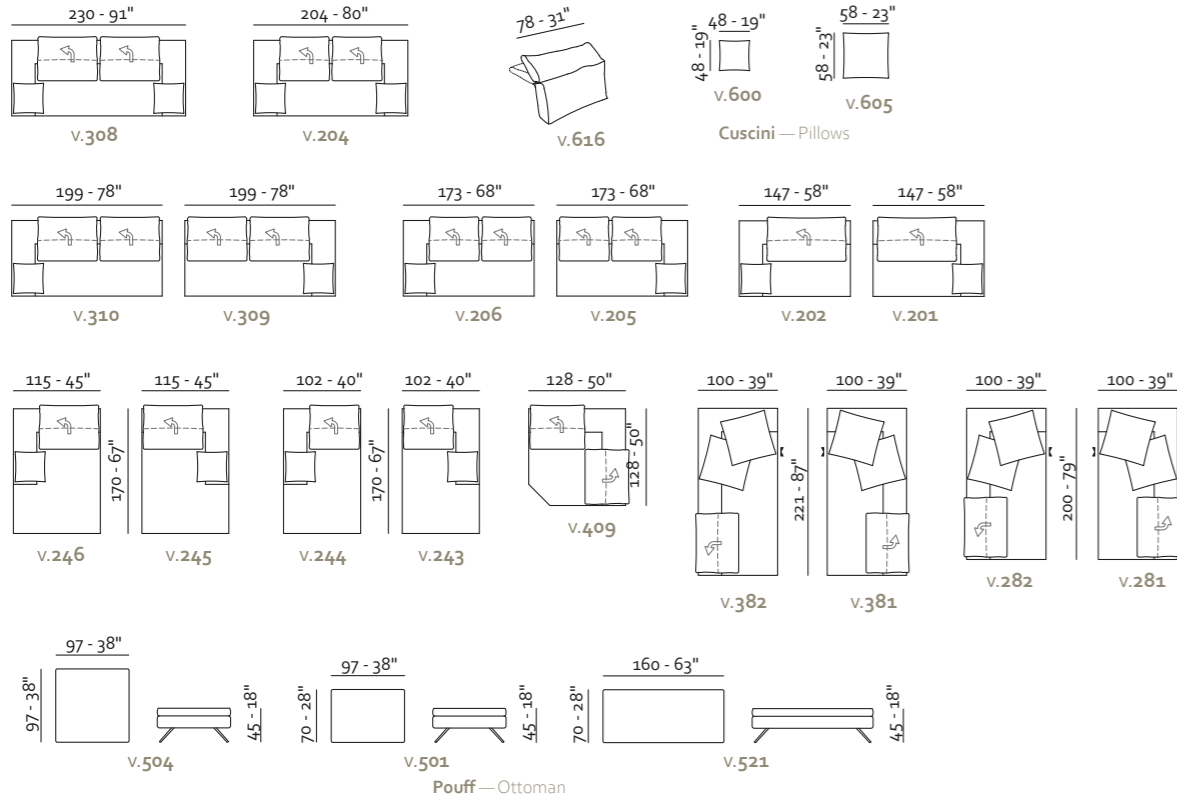

Esempi di componibilità - Sectionals examples - Exemples de compositions - Ejemplos de modularidad

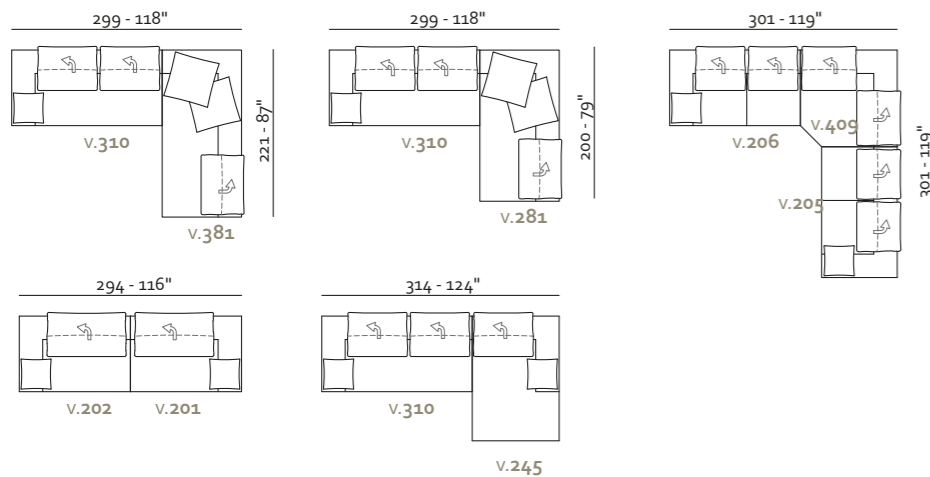

patented model

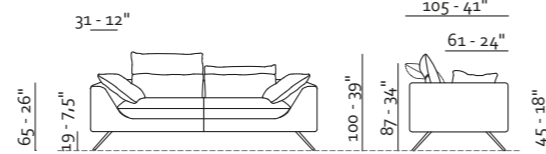

- Rivestimento Pelle / Tessuto Sfoderabile
- Imbottitura BRACCIOLI / Poliuretano espanso / Piuma SEDUTA / Poliuretano espanso / Piuma SPALLIERA / Piuma
- Opzioni Cucitura a contrasto
- Comfort Standard
- Piedi Metallo
- Struttura Telaio in legno

- Coverings Leather / Fabric Removable
- Filling ARMS / Foam / Feather SEAT CUSHION / Foam / Feather BACK CUSHION / Feather
- Options Contrast stitching
- Comfort Standard
- Legs Metal
- Structure Wooden frame

- Revêtement Cuir / Tissu Déhoussable
- Rembourrage ACCOUDOIRS / Mousse / Plumes ASSISE / Mousse / Plumes DOSSIER / Plumes
- Options Coutures contrastées
- Comfort Standard
- Pieds Metal
- Structure Structure en bois

- Revestimiento Piel / Tela Desmontable
- Imbottitura APOYABRAZOS / Poliuretano expandido / Piuma SENTADA / Poliuretano expandido / Piuma RESPALDO / Piuma
- Opciones Costura en contraste
- Comfort Estándar
- Pies Metal
- Struttura Estructura en madera

- Finitura piedi / Legs finishes
- Finition de pieds / Acabados de pies

Speciale_

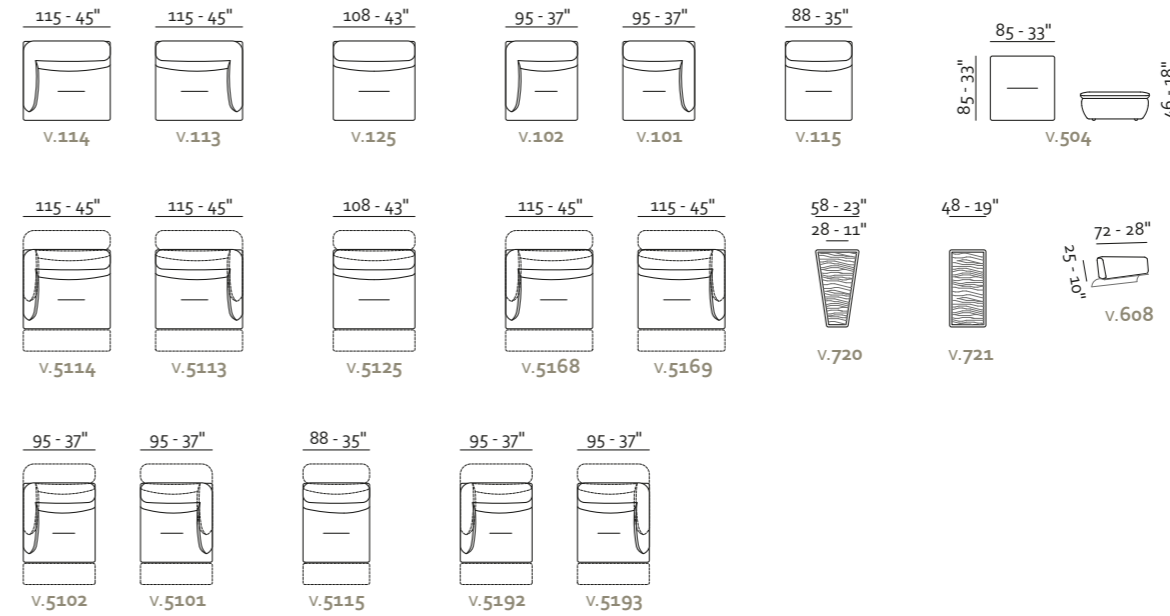

Esempi di componibilità - Sectionals examples - Exemples de compositions - Ejemplos de modularidad

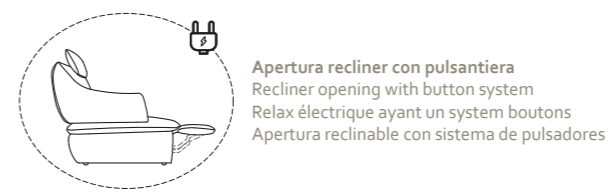
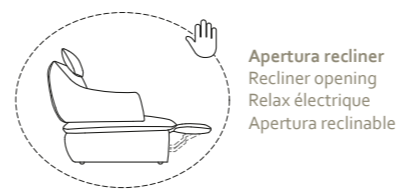
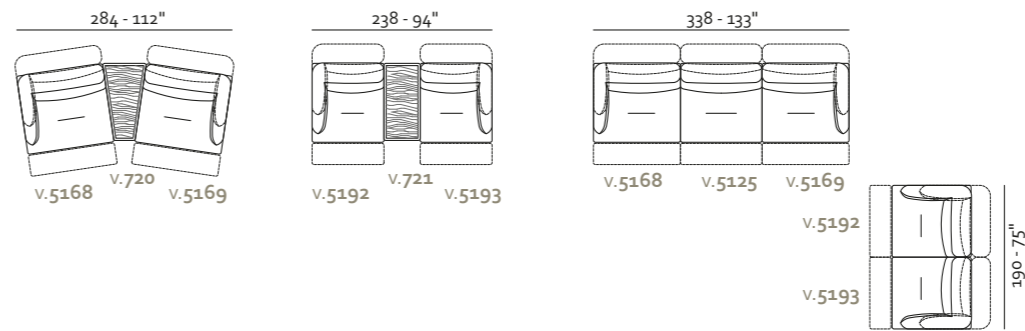

patented model

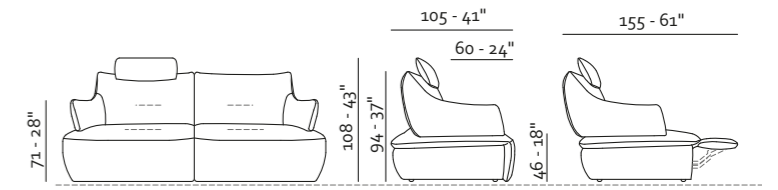

- Rivestimento Pelle / Tessuto
- Imbottitura BRACCIOLI / Poliuretano espanso SEDUTA / Poliuretano espanso SPALLIERA / Poliuretano espanso
- Opzioni Cucitura a contrasto
- Comfort Standard / Rigido
- Piedi Plastica
- Struttura Telaio in legno

- Coverings Leather / Fabric
- Filling ARMS / Foam SEAT CUSHION / Foam BACK CUSHION / Foam
- Options Contrast stitching
- Comfort Standard / Hard
- Legs Plastic
- Structure Wooden frame

- Revêtement Cuir / Tissu
- Rembourrage ACCOUDOIRS / Mousse ASSISE / Mousse DOSSIER / Mousse
- Options Coutures contrastées
- Comfort Standard / Fermé
- Pieds Plastique
- Structure Structure en bois

- Revestimiento Piel / Tela
- Imbottitura APOYABRAZOS / Poliuretano expandido SENTADA / Poliuretano expandido RESPALDO / Poliuretano expandido
- Opciones Costura en contraste
- Comfort Estándar / Duro
- Pies Plástico
- Struttura Estructura en madera

Tender_



Esempi di componibilità - Sectionals examples - Exemples de compositions - Ejemplos de modularidad

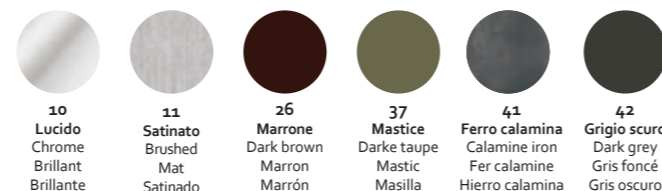
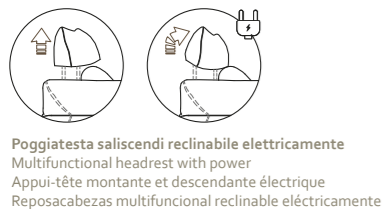
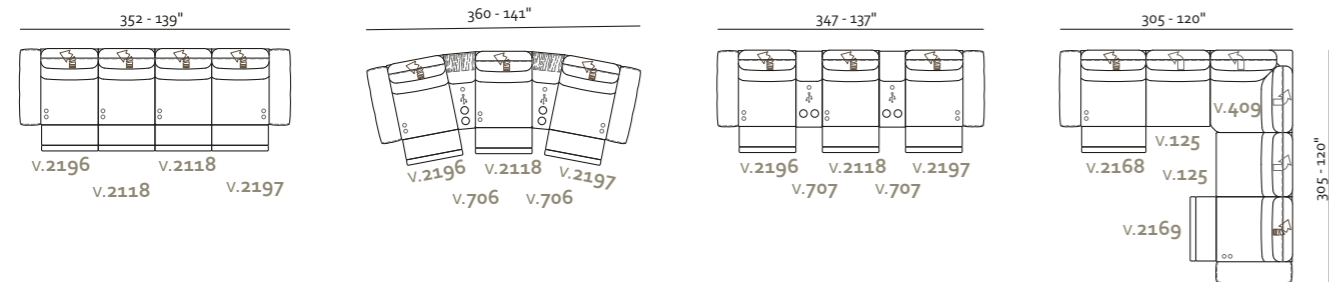

patented model

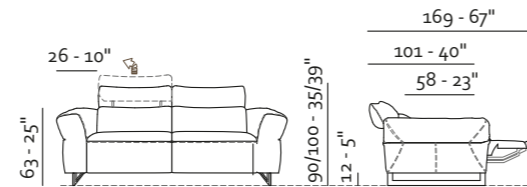

- **Rivestimento** Pelle / Tessuto
- **Imbottitura** BRACCIOLI / Poliuretano espanso
 SEDUTA / Poliuretano espanso
 SPALLIERA / Poliuretano espanso
- **Opzioni** Cucitura a contrasto
- **Comfort Standard**
- **Piedi Metallo**
- **Struttura** Telaio in legno

- **Coverings** Leather / Fabric
- **Filling** ARMS / Foam
 SEAT CUSHION / Foam
 BACK CUSHION / Foam
- **Options** Contrast stitching
- **Comfort Standard**
- **Legs Metal**
- **Structure** Wooden frame

- **Revêtement** Cuir / Tissu
- **Rembourrage** ACCOUDOIRS / Mousse
 ASSISE / Mousse
 DOSSIER / Mousse
- **Options** Coutures contrastées
- **Comfort Standard**
- **Pieds Metal**
- **Structure** Structure en bois

- **Revestimiento** Piel / Tela
- **Imbottitura** APOYABRAZOS / Poliuretano expandido
 SENTADA / Poliuretano expandido
 RESPALDO / Poliuretano expandido
- **Opciones** Costura en contraste
- **Confort Estándar**
- **Pies Metal**
- **Struttura** Estructura en madera

- **Finitura piedi / Legs finishes**
 Finition de pieds / Acabados de pies

Ember_

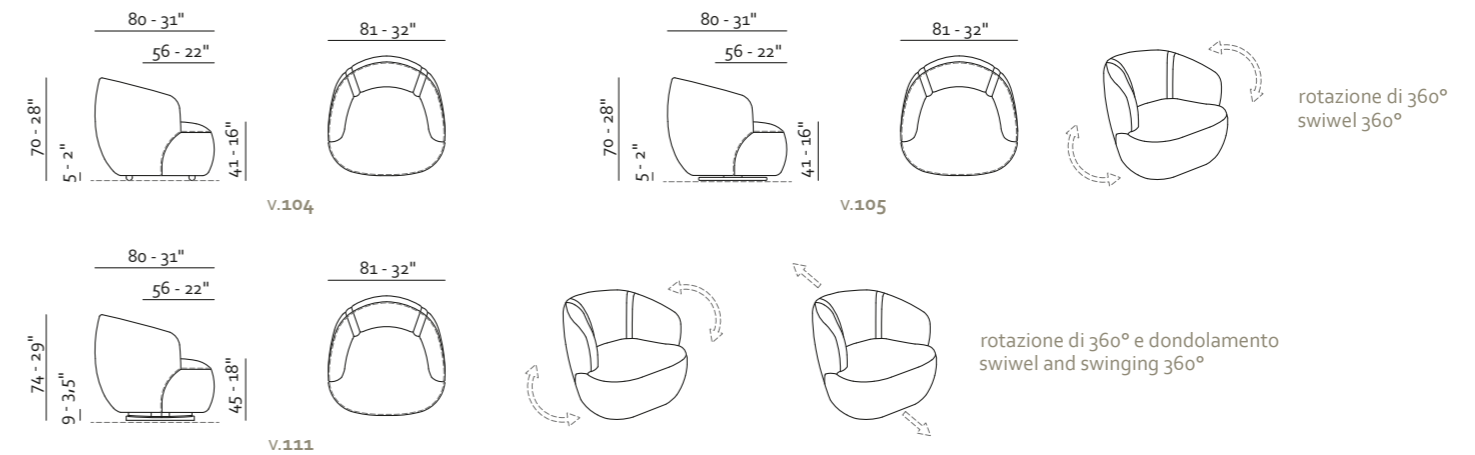

- **Rivestimento** Pelle / Tessuto
- **Imbottitura** BRACCIOLI / Poliuretano espanso
 SEDUTA / Poliuretano espanso
 SPALLIERA / Poliuretano espanso
- **Opzioni** Cucitura a contrasto
- **Comfort Standard**
- **Struttura** Telaio in legno

- **Coverings** Leather / Fabric
- **Filling** ARMS / Foam
 SEAT CUSHION / Foam
 BACK CUSHION / Foam
- **Options** Contrast stitching
- **Comfort Standard**
- **Structure** Wooden frame

- **Revêtement** Cuir / Tissu
- **Rembourrage** ACCOUDOIRS / Mousse
 ASSISE / Mousse
 DOSSIER / Mousse
- **Options** Coutures contrastées
- **Confort Standard**
- **Structure** Structure en bois

- **Revestimiento** Piel / Tela
- **Imbottitura** APOYABRAZOS / Poliuretano expandido
 SENTADA / Poliuretano expandido
 RESPALDO / Poliuretano expandido
- **Opciones** Costura en contraste
- **Confort Estándar**
- **Struttura** Estructura en madera

Muzzle_

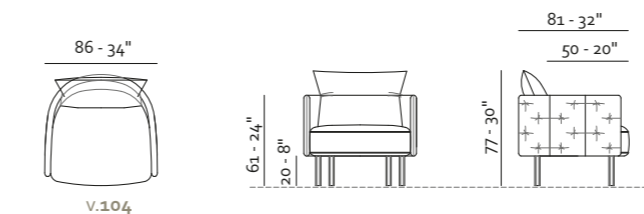

- **Rivestimento** Pelle / Tessuto
- **Imbottitura** BRACCIOLI / Poliuretano espanso
 SEDUTA / Poliuretano espanso
 SPALLIERA / Poliuretano espanso
- **Opzioni** Cucitura a contrasto
- **Comfort Standard**
- **Piedi Metallo**
- **Struttura** Telaio in legno

- **Coverings** Leather / Fabric
- **Filling** ARMS / Foam
 SEAT CUSHION / Foam
 BACK CUSHION / Foam
- **Options** Contrast stitching
- **Comfort Standard**
- **Legs Metal**
- **Structure** Wooden frame

- **Revêtement** Cuir / Tissu
- **Rembourrage** ACCOUDOIRS / Mousse
 ASSISE / Mousse
 DOSSIER / Mousse
- **Options** Coutures contrastées
- **Confort Standard**
- **Pieds Metal**
- **Structure** Structure en bois

- **Revestimiento** Piel / Tela
- **Imbottitura** APOYABRAZOS / Poliuretano expandido
 SENTADA / Poliuretano expandido
 RESPALDO / Poliuretano expandido
- **Opciones** Costura en contraste
- **Confort Estándar**
- **Pies Metal**
- **Struttura** Estructura en madera

— Finitura piedi / Legs finishes Finition de pieds / Acabados de pies

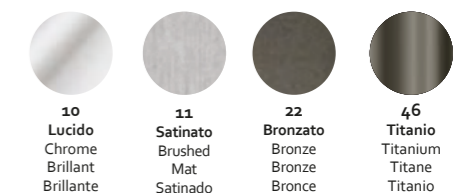

patented model

Scott_

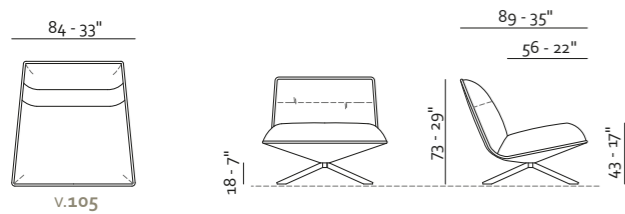

- Rivestimento
Pelle / Tessuto
- Imbottitura
SEDUTA / Poliuretano espanso
SPALLIERA / Poliuretano espanso
- Opzioni Cucitura a contrasto
- Comfort Standard
- Piedi Metallo
- Struttura Telaio in legno

- Coverings
Leather / Fabric
- Filling
SEAT CUSHION / Foam
BACK CUSHION / Foam
- Options Contrast stitching
- Comfort Standard
- Legs Metal
- Structure Wooden frame

- Revêtement
Cuir / Tissu
- Rembourrage
ASSISE / Mousse
DOSSIER / Mousse
- Options Coutures contrastées
- Comfort Standard
- Pieds Metal
- Structure Structure en bois

- Revestimiento
Piel / Tela
- Imbottitura
SENTADA / Poliuretano expandido
RESPALDO / Poliuretano expandido
- Opciones Costura en contraste
- Comfort Estándar
- Pies Metal
- Struttura Estructura en madera

— Finitura piedi / Legs finishes
Finition de pieds / Acabados de pies

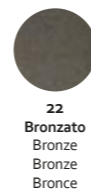

22
Bronzato
Bronze
Bronze
Bronce

Yuma

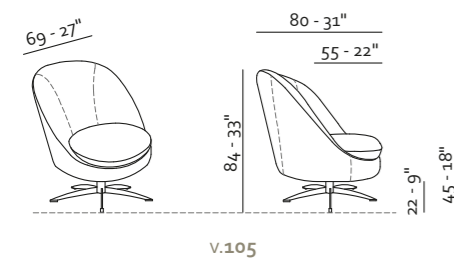

- Rivestimento
Pelle / Tessuto
- Imbottitura
SEDUTA / Poliuretano espanso
SPALLIERA / Poliuretano espanso
- Opzioni Cucitura a contrasto
- Comfort Standard
- Piedi Metallo
- Struttura Telaio in legno

- Coverings
Leather / Fabric
- Filling
SEAT CUSHION / Foam
BACK CUSHION / Foam
- Options Contrast stitching
- Comfort Standard
- Legs Metal
- Structure Wooden frame

- Revêtement
Cuir / Tissu
- Rembourrage
ASSISE / Mousse
DOSSIER / Mousse
- Options Coutures contrastées
- Comfort Standard
- Pieds Metal
- Structure Structure en bois

- Revestimiento
Piel / Tela
- Imbottitura
SENTADA / Poliuretano expandido
RESPALDO / Poliuretano expandido
- Opciones Costura en contraste
- Comfort Estándar
- Pies Metal
- Struttura Estructura en madera

— Finitura piedi / Legs finishes
Finition de pieds / Acabados de pies

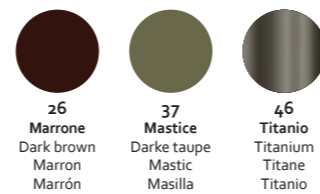

26
Marrone
Dark brown
Marron
Marrón

37
Mastice
Dark taupe
Mastic
Masilla

46
Titanio
Titanium
Titane
Titanio

patented model

Muzzle bed_



Misure Europee - European Sizes

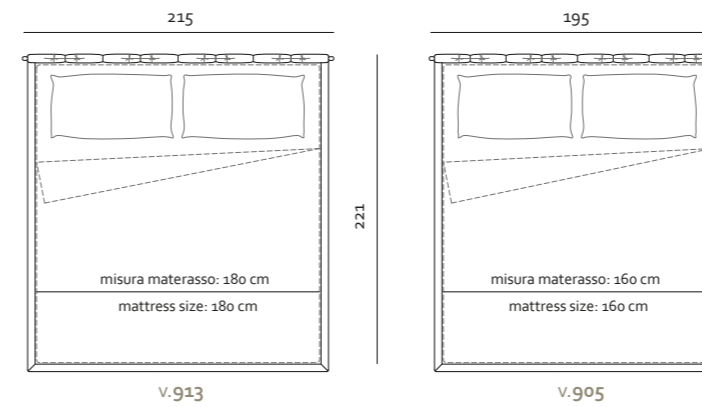

Misure Americane - American Sizes

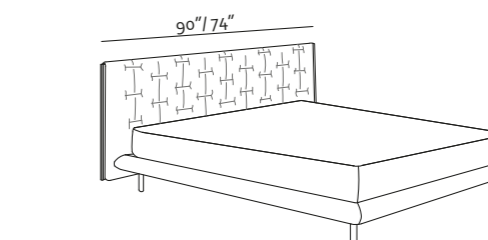
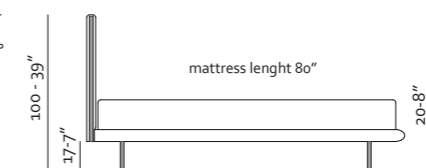
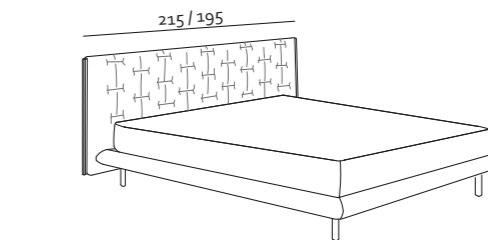
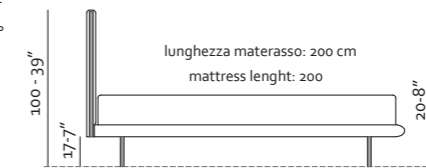
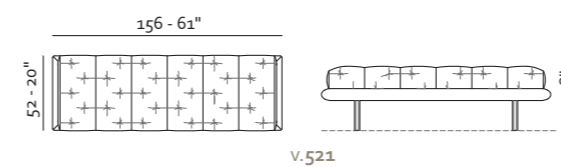
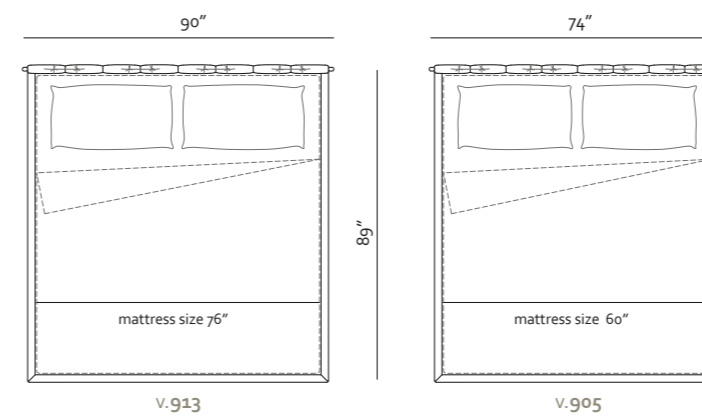

patented model

- Rivestimento
Pelle / Tessuto
- Imbottitura
Poliuretano espanso
- Piedi Metallo
- Struttura Telaio in legno

- Coverings
Leather / Fabric
- Filling
Foam
- Legs Metal
- Structure Wooden frame

- Revêtement
Cuir / Tissu
- Rembourrage
Mousse
- Pieds Metal
- Structure Structure en bois

- Revestimiento
Piel / Tela
- Imbottitura
Poliuretano expandido
- Pies Metal
- Struttura Estructura en madera

— Finitura piedi / Legs finishes
Finition de pieds / Acabados de pies

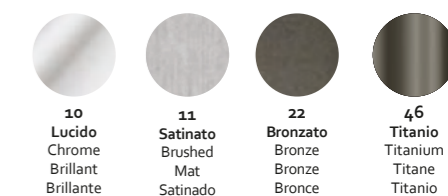

10
Lucido
Chrome
Brilliant
Brillante

11
Satinato
Brushed
Mat
Satinado

22
Bronzato
Bronze
Bronze
Bronce

46
Titanio
Titanium
Titane
Titanio

Nel bed_



Misure Europee - European Sizes

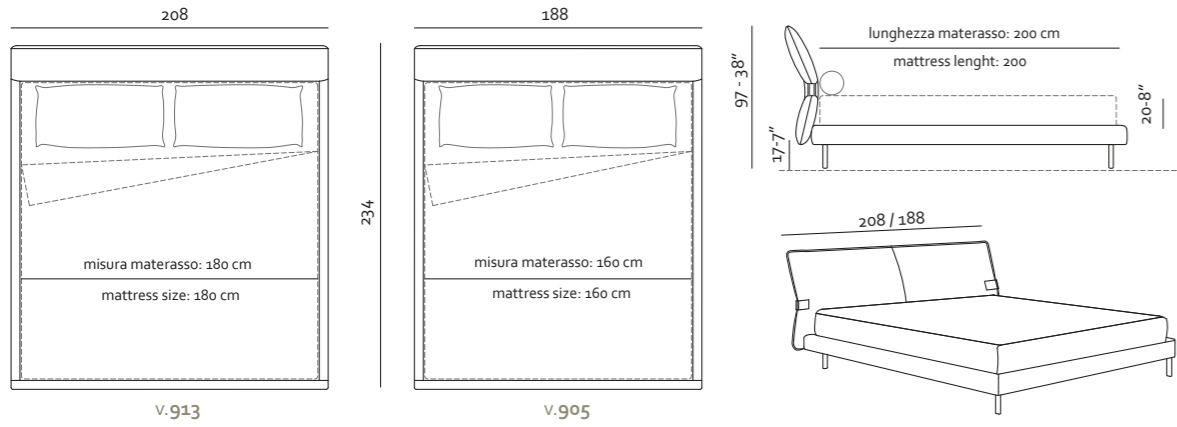

Misure Americane - American Sizes

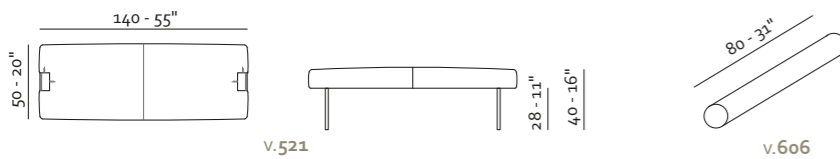
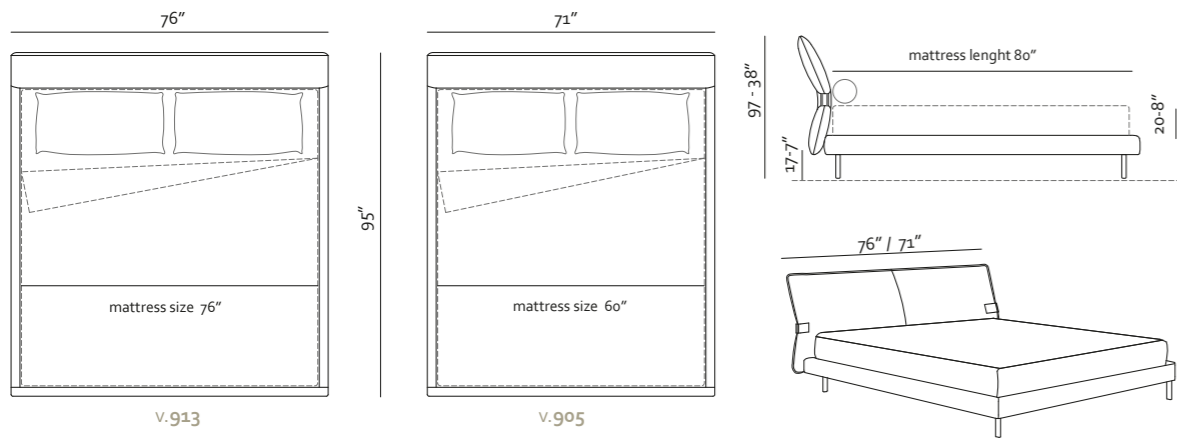

patented model

- Rivestimento
Pelle / Tessuto
- Imbottitura
Poliuretano espanso
- Piedi Metallo
- Struttura Telaio in legno

- Coverings
Leather / Fabric
- Filling
Foam
- Legs Metal
- Structure Wooden frame

- Revêtement
Cuir / Tissu
- Rembourrage
Mousse
- Pieds Metal
- Structure Structure en bois

- Revestimiento
Piel / Tela
- Imbottitura
Poliuretano expandidor
- Pies Metal
- Struttura Estructura en madera

- Finitura piedi / Legs finishes
Finition de pieds / Acabados de pies



Leia_

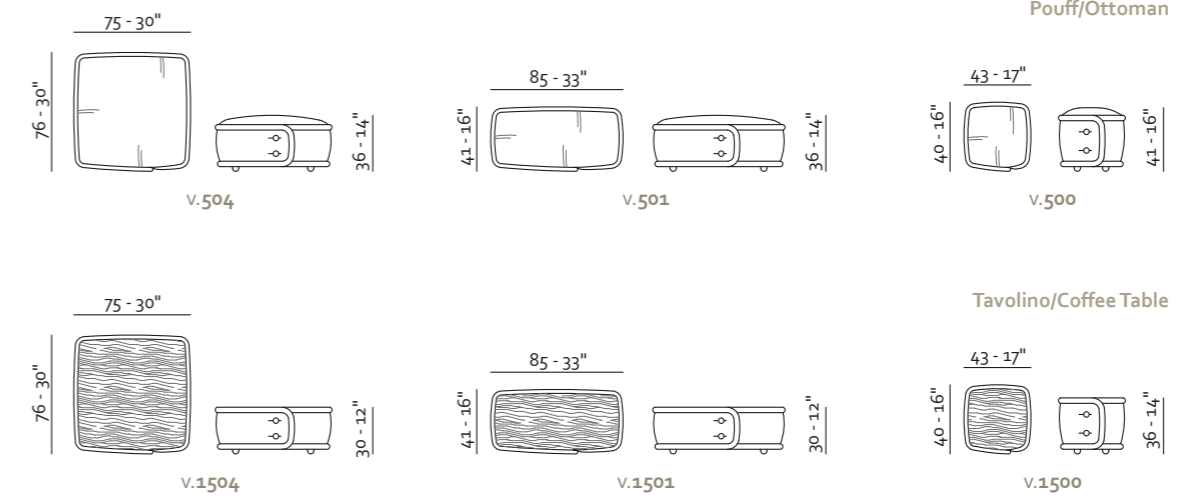

Pouff/Ottoman

Tavolino/Coffee Table

- Finitura ripiano / Table finishes
Finition table / Acabados tablas



patented model

Muzzle_

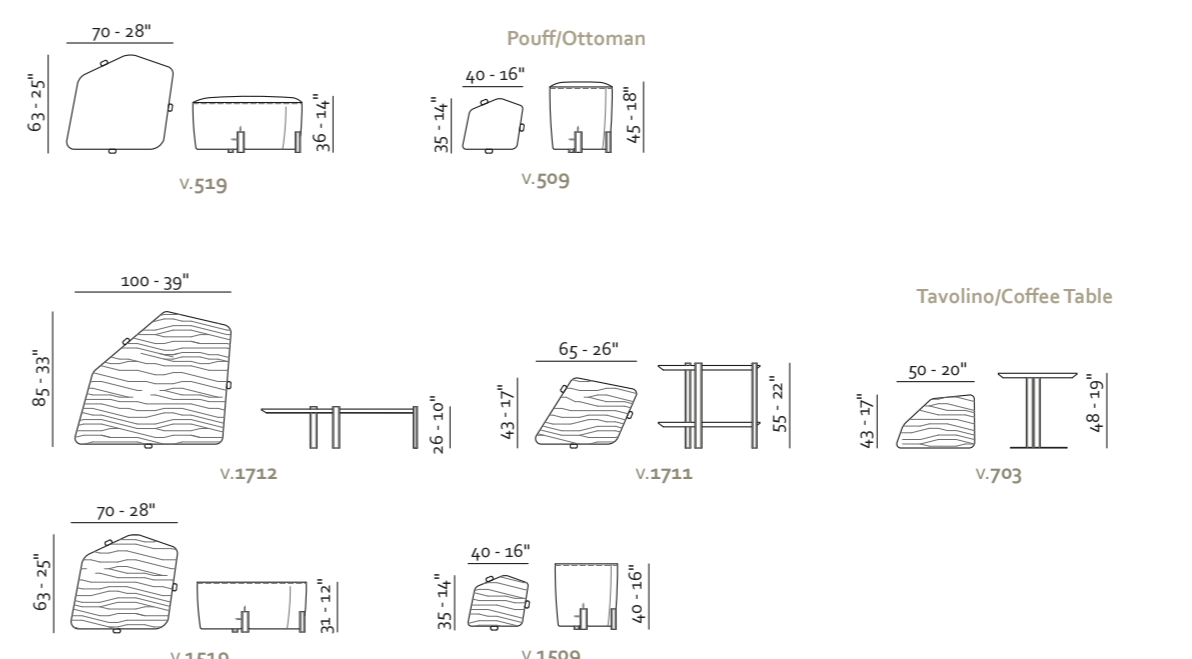

Pouff/Ottoman

Tavolino/Coffee Table

- Finitura piedi / Legs finishes
Finition de pieds / Acabados de pies

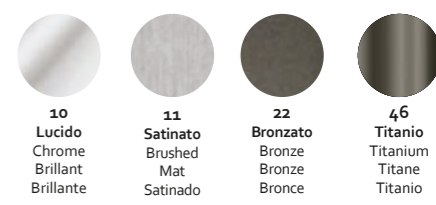

- Finitura ripiano / Table finishes
Finition table / Acabados tablas



Nel_



Pouff/Ottoman

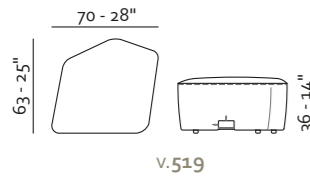

V.519

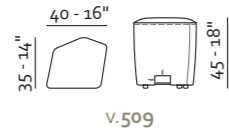

V.509

Tavolino/Coffee Table

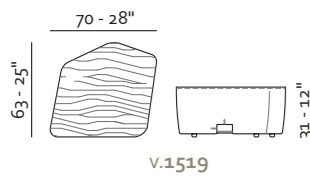

V.1519

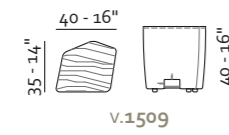

V.1509

patented model

— Finitura piedi / Legs finishes
Finition de pieds / Acabados de pies

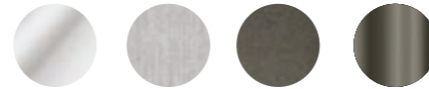

10 Lucido
Chrome
Brillant
Brillante

11 Satinato
Brushed
Mat
Satinado

22 Bronzato
Bronze
Bronce

46 Titanio
Titanium
Titane
Titanio

— Finitura ripiano / Table finishes
Finition table / Acabados tablas



18 Noce Canaletto
Canaletto walnut
Bois noyer canaletto
Madera de nogal

88 Gres LUNAR

89 Gres TYROL

Pocket_ - cuscini/pillows

Pocket 01



Rivestimento - Coverings - Revêtement - Revestimiento
Pelle - Leather - Cuir - Piel / Tessuto - Fabric - Tissue - Tela
Imbottitura - Filling - Rembourrage - Imbottitura
Piuma - Feather - Plumes - Pluma

55x40 cm - 22"x16"

Pocket 02



Rivestimento - Coverings - Revêtement - Revestimiento
Pelle - Leather - Cuir - Piel / Tessuto - Fabric - Tissue - Tela
Imbottitura - Filling - Rembourrage - Imbottitura
Piuma - Feather - Plumes - Pluma

50x35 cm - 20"x14"

Pocket 03



Rivestimento - Coverings - Revêtement - Revestimiento
Pelle - Leather - Cuir - Piel / Tessuto - Fabric - Tissue - Tela
Imbottitura - Filling - Rembourrage - Imbottitura
Piuma - Feather - Plumes - Pluma

55x30 cm - 22"x 12"

Pocket 04



Rivestimento - Coverings - Revêtement - Revestimiento
Pelle - Leather - Cuir - Piel / Tessuto - Fabric - Tissue - Tela
Imbottitura - Filling - Rembourrage - Imbottitura
Piuma - Feather - Plumes - Pluma

50x35 cm - 20"x 14"

Pocket 05



Rivestimento - Coverings - Revêtement - Revestimiento
Pelle - Leather - Cuir - Piel / Tessuto - Fabric - Tissue - Tela
Imbottitura - Filling - Rembourrage - Imbottitura
Piuma - Feather - Plumes - Pluma

40x40 cm - 16"x 16"

Tarkin_



Pouff/Ottoman

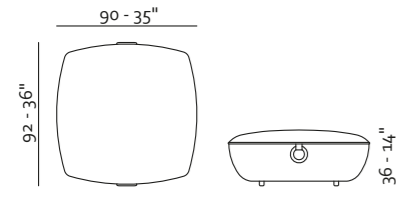

V.515

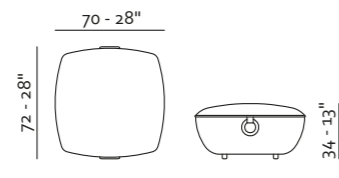

V.505

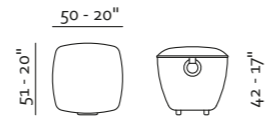

V.502

Tavolino/Coffee Table

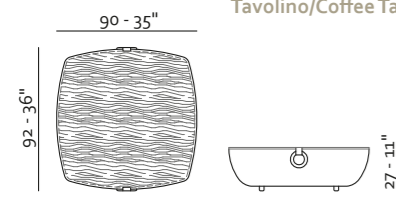

V.1515

patented model

— Finitura ripiano / Table finishes
Finition table / Acabados tablas



18 Noce Canaletto
Canaletto walnut
Bois noyer canaletto
Madera de nogal

88 Gres LUNAR

89 Gres TYROL

Skid_ - tappeti/rugs

Dune_

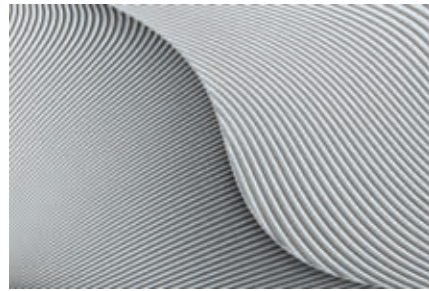

dimensione/ size
300x200 cm / 118"x79"

color **grigio/grey**
code **103SKID19994**

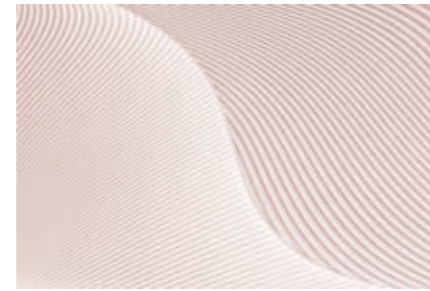

dimensione/ size
300x200 cm / 118"x79"

color **rosa/pink**
code **103SKID29994**

Flash_



dimensione/ size
300x200 cm / 118"x79"

color **beige**
code **103SKID39994**



dimensione/ size
300x200 cm / 118"x79"

color **grigio blu/grey blue**
code **103SKID49994**

Fluid_



dimensione/ size
300x200 cm / 118"x79"

color **verde/green**
code **103SKID59994**



dimensione/ size
300x200 cm / 118"x79"

color **beige**
code **103SKID69994**

Stilness_

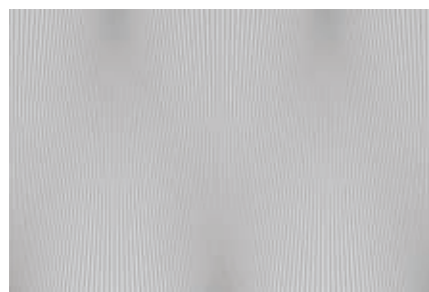

dimensione/ size
300x200 cm / 118"x79"

color **grigio/grey**
code **103SKID79994**

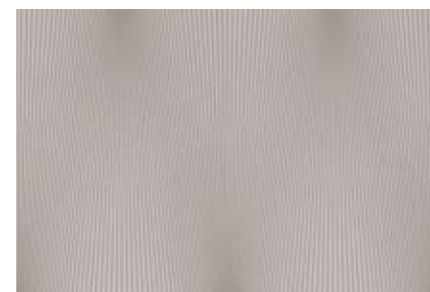

dimensione/ size
300x200 cm / 118"x79"

color **marrone/brown**
code **103SKID19994**

 **maxdivani**



Maxdivani S.r.l.
Largo Epitaffio, 1
70022 Altamura (Ba)
Tel. +39 080 926 6200
info@maxdivani.it
maxdivani.it

Stampato in Italia - Ottobre 2022
Printed in Italy - October 2022

La MAXDIVANI s.r.l. si riserva la facoltà di modificare in qualunque momento e senza preavviso, le caratteristiche tecniche degli elementi usati nel presente catalogo. Le misure riportate nei grafici possono subire variazioni dovute alla manifattura. Alcuni accessori presenti nelle immagini fotografiche non sono prodotti dalla MAXDIVANI s.r.l.
Il presente catalogo è tutelato dalla legge sui diritti d'Autore (legge 22.4.1941, n° 633 e della legge 14.12.1942, n° 1485); e successive modifiche, di esso è proibita ogni riproduzione, totale o anche parziale in Italia o all'estero.

MAXDIVANI s.r.l. reserves the right to modify in any moment and without notice the technical characteristics of the elements used in this catalogue. Some dimensions reported in the schematics may be subject to modifications due to manufacturing. Some of the accessories shown in the pictures are not produced by MAXDIVANI s.r.l. This catalogue is protected by the law on Author's Rights (law dated 22.04.1941, no. 633 and by the law dated 14.12.1942, no. 1485); and its following modifications. Any reproduction, complete or in part, is forbidden in Italy and abroad.

MAXDIVANI s.r.l. se réserve le droit de modifier à tout moment et sans préavis les caractéristiques techniques des éléments utilisés dans ce catalogue. Les mesures montrées dans les graphiques peuvent subir des variations dues à la fabrication. Certains accessoires présents dans les images photographiques ne sont pas produits par MAXDIVANI srl.
Ce catalogue est protégé par la loi sur les droits d'auteur (loi 22.4.1941, loi n° 633 et loi 14.12.1942, n° 1485); telle que modifiée.
Il est interdit toute reproduction, totale ou même partielle en Italie ou à l'étranger.

El MAXDIVANI s.r.l. se reserva el derecho de modificar en cualquier momento y sin previo aviso las características técnicas de los elementos utilizados en este catálogo. Las medidas que se muestran en los gráficos pueden sufrir variaciones debido a la fabricación. Algunos accesorios presentes en las imágenes fotográficas no son producidos por MAXDIVANI s.r.l.
Este catálogo está protegido por la ley de derechos de autor (ley 22.4.1941, n° 633 y ley 14.12.1942, n° 1485) Está prohibido cualquier reproducción, total o parcial en Italia o en el extranjero.



Maxdivani s.r.l. | Largo Epitaffio, 1 - 70022 Altamura (BA) Italy | +39 080 9266200 | info@maxdivani.it | www.maxdivani.it